

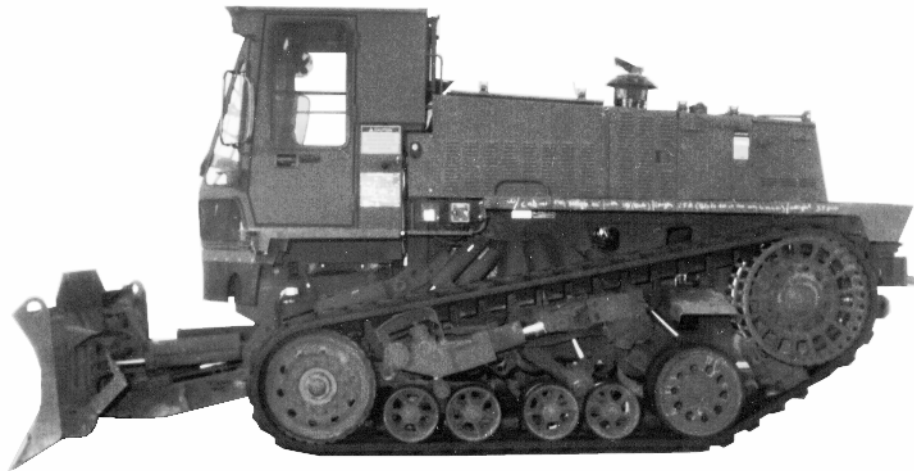

AIRDROP OF SUPPLIES AND EQUIPMENT:

RIGGING TRACTORS AND TRACTOR-DOZERS



MARCH 2003

DISTRIBUTION RESTRICTION: Approved for public release; distribution is unlimited.

**HEADQUARTERS
DEPARTMENT OF THE ARMY
DEPARTMENT OF THE AIR FORCE**

FIELD MANUAL
No. 4-20.121
TECHNICAL ORDER
No. 13C7-6-21

HEADQUARTERS
DEPARTMENT OF THE ARMY
DEPARTMENT OF THE AIR FORCE
Washington, DC, 20 March 2003

**AIRDROP OF SUPPLIES AND EQUIPMENT:
RIGGING TRACTORS AND TRACTOR-DOZERS**

TABLE OF CONTENTS

	Paragraph	Page
PREFACE		iii
CHAPTER 1 INTRODUCTION		
Description of Items.....	1-1	1-1
Special Considerations	1-2	1-1
CHAPTER 2 RIGGING THE TYPE I, D-5B TRACTOR-DOZER FOR LOW-VELOCITY AIRDROP		
Description of Load.....	2-1	2-1
Preparing Platform.....	2-2	2-1
Building and Positioning Honeycomb Stacks	2-3	2-3
Preparing Dozer.....	2-4	2-16
Installing Suspension Slings	2-5	2-23
Lifting and Positioning Dozer.....	2-6	2-24
Lashing Dozer	2-7	2-25
Padding and Securing Hydraulic Cylinders	2-8	2-30
Installing Load Cover.....	2-9	2-31
Installing Deadman's Tie.....	2-10	2-31
Safety Tying Suspension Slings	2-11	2-31
Safety Tying Load Spreader	2-12	2-31
Stowing Cargo Parachutes.....	2-13	2-32
Installing the Release System	2-14	2-35
Installing the Extraction System	2-15	2-37
Installing Provisions for Emergency Restraints	2-16	2-38
Placing Extraction Parachutes	2-17	2-38
Marking Rigged Load.....	2-18	2-38
Equipment Required	2-19	2-38

DISTRIBUTION RESTRICTION: Approved for public release; distribution is unlimited.

* This publication supersedes FM 10-521/TO 13C7-6-21, 7 October 1987.

CHAPTER 3 RIGGING THE JOHN DEERE 450G LT TRACKED COMMERCIAL BULL-DOZER ON A 16-FOOT, TYPE V PLATFORM FOR LOW-VELOCITY AIRDROP

	Paragraph	Page
Description of Load	3-1	3-1
Preparing Platform	3-2	3-1
Building and Positioning Honeycomb Stacks	3-3	3-3
Preparing Dozer	3-4	3-9
Lifting and Positioning Dozer	3-5	3-13
Lashing Dozer to Platform	3-6	3-14
Installing Suspension Slings, Deadman's Tie and Load Cover	3-7	3-16
Building and Positioning Parachute Stowage Platform Support Stacks	3-8	3-17
Building Parachute Stowage Platform	3-9	3-18
Installing Parachute Stowage Platform, Preparing and Stowing Cargo Parachutes.....	3-10	3-19
Installing Extraction System	3-11	3-20
Installing Parachute Release	3-12	3-21
Placing Extraction Parachute	3-13	3-22
Installing Provisions for Emergency Restraints	3-14	3-22
Marking Rigged Load	3-15	3-22
Equipment Required	3-16	3-22

CHAPTER 4 RIGGING THE DEPLORABLE UNIVERSAL COMBAT EARTHMOVER (DEUCE) ON A 24-FOOT, TYPE V PLATFORM FOR LOW-VELOCITY AIRDROP

Description of Load	4-1	4-1
Preparing Platform	4-2	4-1
Building and Positioning Honeycomb Stacks	4-3	4-3
Preparing the DEUCE	4-4	4-12
Lifting and Positioning the DEUCE	4-5	4-17
Lashing Load to Platform	4-6	4-25
Installing the Rear Step Box and Load Cover	4-7	4-32
Installing Suspension Slings and Deadman's Tie	4-8	4-33
Building and Positioning Parachute Stowage Platform	4-9	4-35
Preparing and Stowing Cargo Parachutes	4-10	4-36
Installing Extraction System	4-11	4-37
Installing Parachute Release	4-12	4-38
Placing Extraction Parachute	4-13	4-39
Installing Provisions for Emergency Restraint	4-14	4-39
Marking Rigged Load	4-15	4-39
Equipment Required	4-16	4-39

GLOSSARY Glossary-1

REFERENCES References-1

PREFACE

SCOPE

This manual tells and shows how to prepare and rig the D-5B (Type I) tractor-dozer which is rigged for low-velocity (LV) airdrop from a C-130, C-5, C-17, and C-141 aircraft. The John Deere 450G LT full-tracked commercial bulldozer is rigged for LV airdrop from a C-130, C-141, C-5, and C-17 aircraft. The Deployable Universal Combat Earthmover (DEUCE) is rigged for LV airdrop from a C-130, C-5, and C-17 and C-141 aircraft.

USER INFORMATION

The proponent of this publication is HQ TRADOC. You are encouraged to report any errors or omissions and to suggest ways to make this a better manual. Army personnel, send your comments on DA Form 2028 directly to:

Director
Aerial Delivery and Field Services Department
USA Quartermaster Center and School
1010 Shop Road
Fort Lee, Virginia 23801-1502

Air Force personnel, send your reports on AFTO Form 22 through:

Headquarters
Air Mobility Command (AMC/DOKT)
402 Scott Drive, Unit 3A1
Scott AFB, Illinois 62225-5302

Air Force personnel in Special Operations Command, send your reports on AFTO Form 22 through:

HQ AFSOC/DOXT
100 Bartley St., Suite 2260
Hurlburt Field, Florida 32544-5273

to:

Director
Aerial Delivery and Field Services Department
USA Quartermaster Center and School
1010 Shop Road
Fort Lee, Virginia 23801-1502

Also send information copy of AFTO Form 22 to:

WR-ALC/LKCB
460 Richard Ray Blvd Suite 221
Robbins AFB, GA 31098-1640

Unless this publication states otherwise, masculine nouns and pronouns do not refer exclusively to men.

Chapter 1

INTRODUCTION

DESCRIPTION OF ITEMS

1-1. The description and unrigged data for the items covered in this manual are described below.

a. D-5B Tractor-Dozer. D-5B, type I (nonsectionalized). The type I tractor-dozer weighs 31,350 pounds with 3/4 tank of fuel. The weight of the tractor-dozer is reducible to 30,105 pounds with the roll-over protection structure (ROPS) removed. The tractor-dozer is 225 inches in length. Its width is 104 inches with the blade angled, and its height is 121 inches (reducible to 82 inches).

b. John Deere 450G Lt Full-Track Commercial Bulldozer. The John Deere 450G Lt bulldozer weighs 18,080 pounds. The dozer is 180 inches in length. Its width is 97 inches and its height is 108 inches (reducible to 77 inches with ROPS removed and the seat back lowered).

c. Deployable Universal Combat Earthmover (DEUCE). The Deployable Universal Combat Earthmover weighs 35,000 pounds. The earthmover is 112 inches high (reducible to 90 inches in the kneeling position with the cab removed).

SPECIAL CONSIDERATIONS

1-2. Special considerations for this manual are given below.

a. The loads covered in this manual may include hazardous materials as defined in AFMAN(I) 24-204/TM 38-250. If included, the hazardous materials must be packaged, marked, and labeled as required by AFMAN(I) 24-204/TM 38-250.

b. A copy of this manual must be available to the joint airdrop inspectors during the before- and after-loading inspection.

Chapter 2

RIGGING THE TYPE I, D-5B TRACTOR-DOZER FOR LOW-VELOCITY AIRDROP

DESCRIPTION OF LOAD

2-1. The type I (nonsectional), D-5B tractor-dozer is rigged on a 24-foot, type V platform with eight G-11 cargo parachutes. This dozer may be delivered by low-velocity airdrop from C-130, C-5, C-17, or C-141 aircraft.

PREPARING PLATFORM

2-2. Prepare a 24-foot, type V platform using two tandem links and 68 tiedown clevises as shown in Figure 2-1.

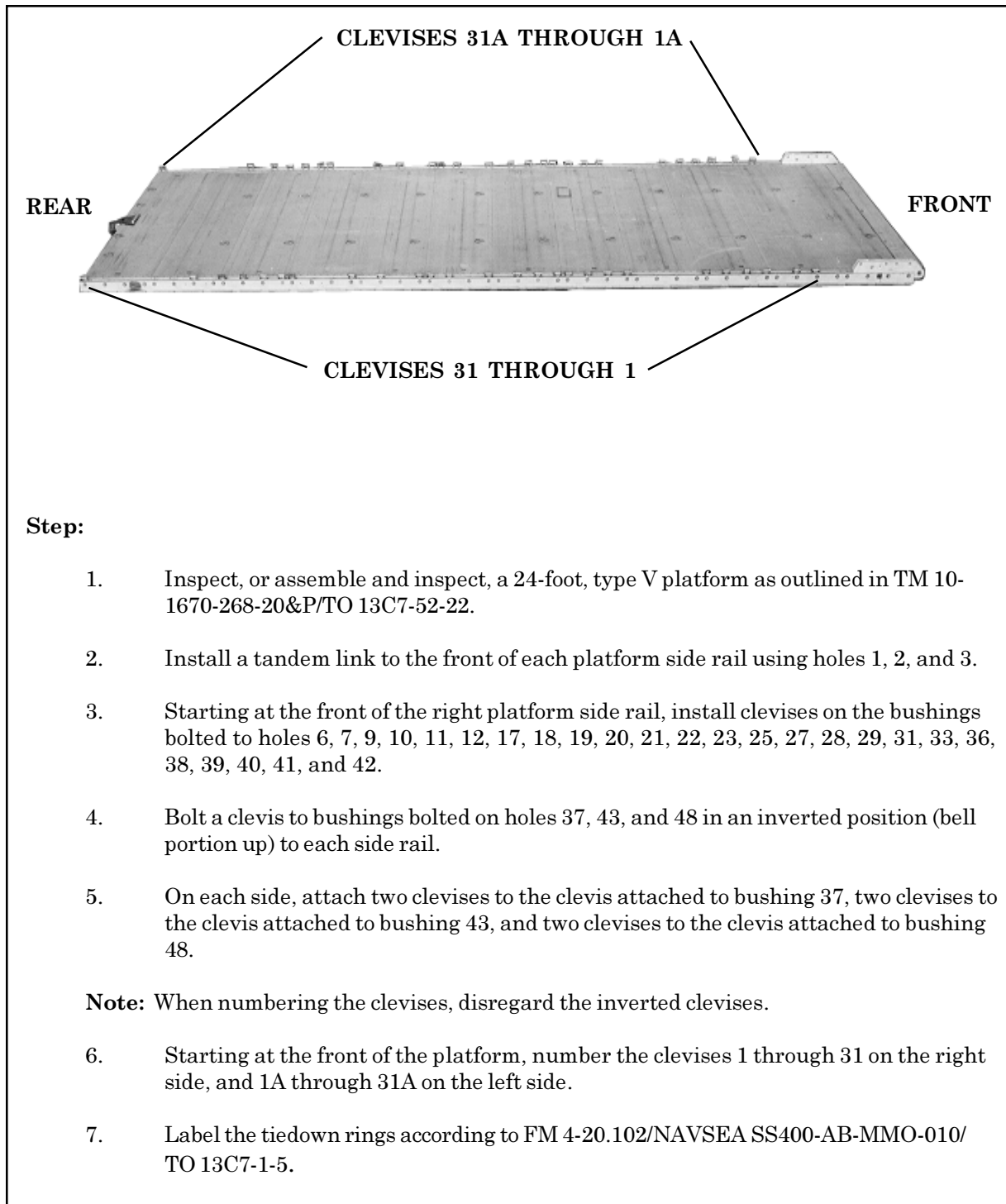

Step:

1. Inspect, or assemble and inspect, a 24-foot, type V platform as outlined in TM 10-1670-268-20&P/TO 13C7-52-22.
2. Install a tandem link to the front of each platform side rail using holes 1, 2, and 3.
3. Starting at the front of the right platform side rail, install clevises on the bushings bolted to holes 6, 7, 9, 10, 11, 12, 17, 18, 19, 20, 21, 22, 23, 25, 27, 28, 29, 31, 33, 36, 38, 39, 40, 41, and 42.
4. Bolt a clevis to bushings bolted on holes 37, 43, and 48 in an inverted position (bell portion up) to each side rail.
5. On each side, attach two clevises to the clevis attached to bushing 37, two clevises to the clevis attached to bushing 43, and two clevises to the clevis attached to bushing 48.

Note: When numbering the clevises, disregard the inverted clevises.

6. Starting at the front of the platform, number the clevises 1 through 31 on the right side, and 1A through 31A on the left side.
7. Label the tiedown rings according to FM 4-20.102/NAVSEA SS400-AB-MMO-010/TO 13C7-1-5.

Figure 2-1. Platform Prepared

BUILDING AND POSITIONING HONEYCOMB STACKS

2-3. Build the load spreader for the honeycomb stacks as shown in Figure 2-2. Build the honeycomb stacks as shown in Figures 2-3 through 2-8. Position the stacks as shown in Figures 2-9 through 2-13.

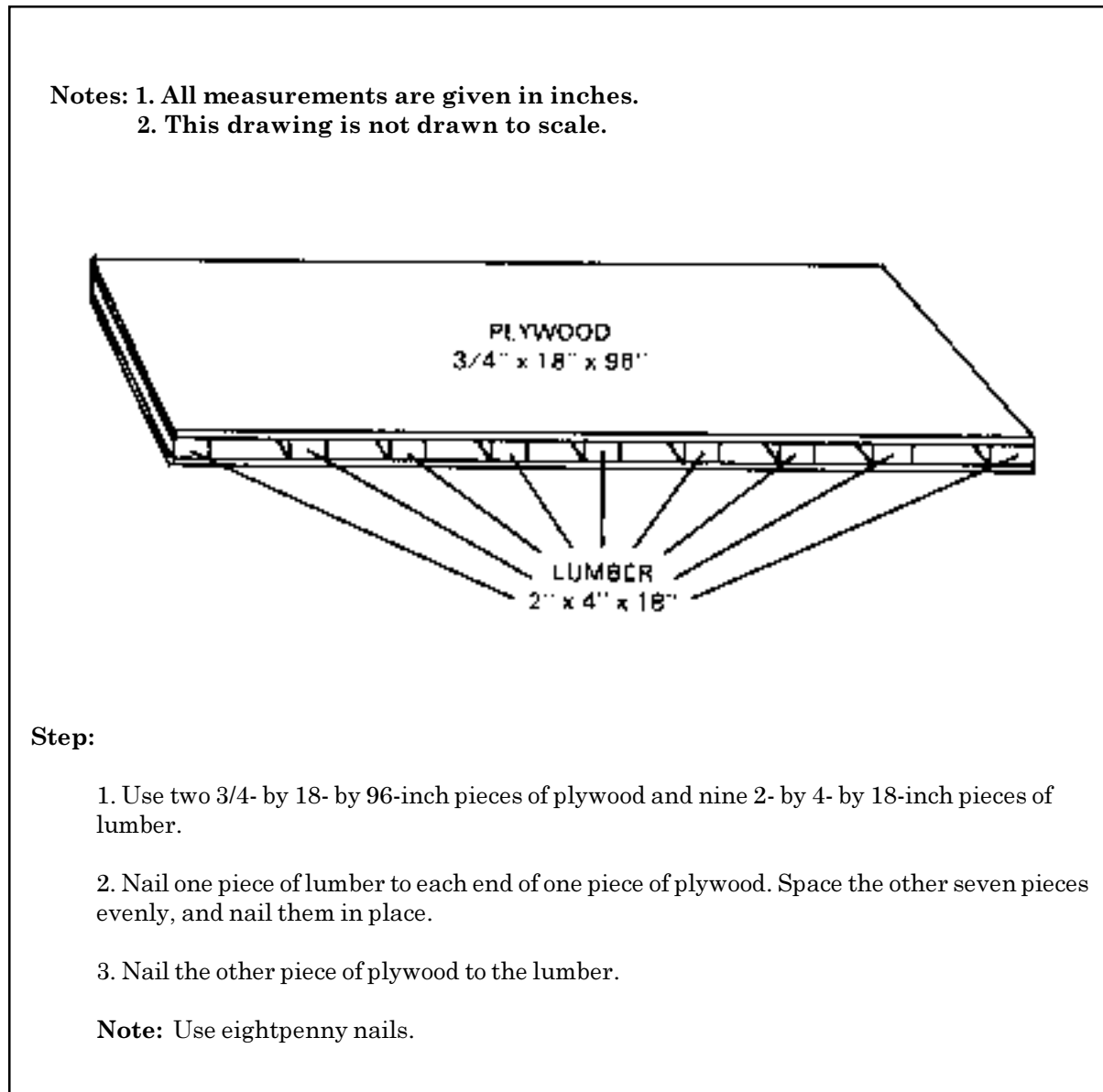
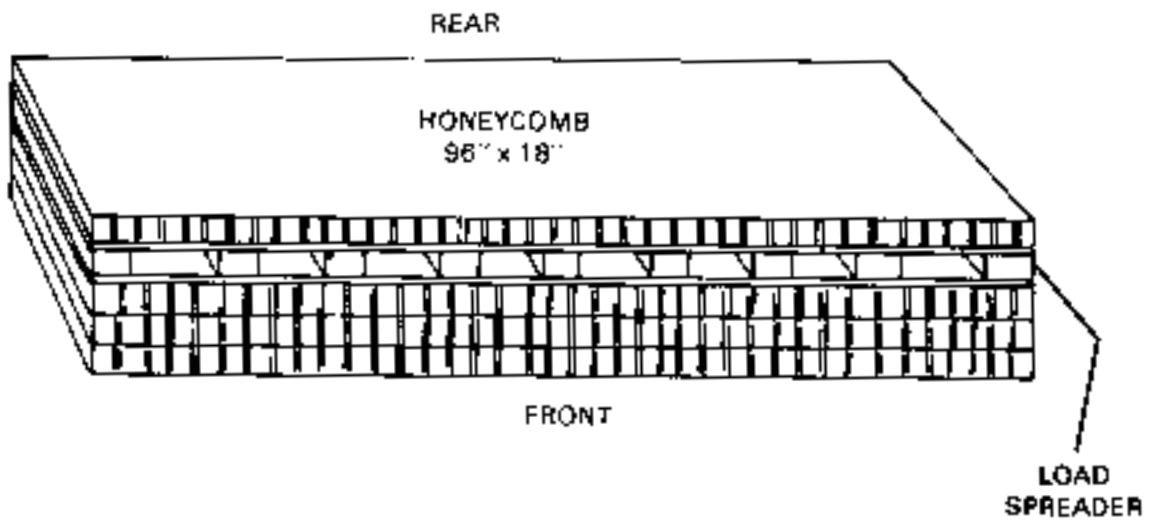

Figure 2-2. Load Spreader Prepared

- Notes: 1. All measurements are given in inches.
 2. This drawing is not drawn to scale.



Stack Number	Pieces	Width (Inches)	Length (Inches)	Material	Instructions
1	4	96 96	18 18	Honeycomb Load spreader	Form base stack. Place load spreader under the top piece of honeycomb.

Figure 2-3. Honeycomb Stack I Prepared

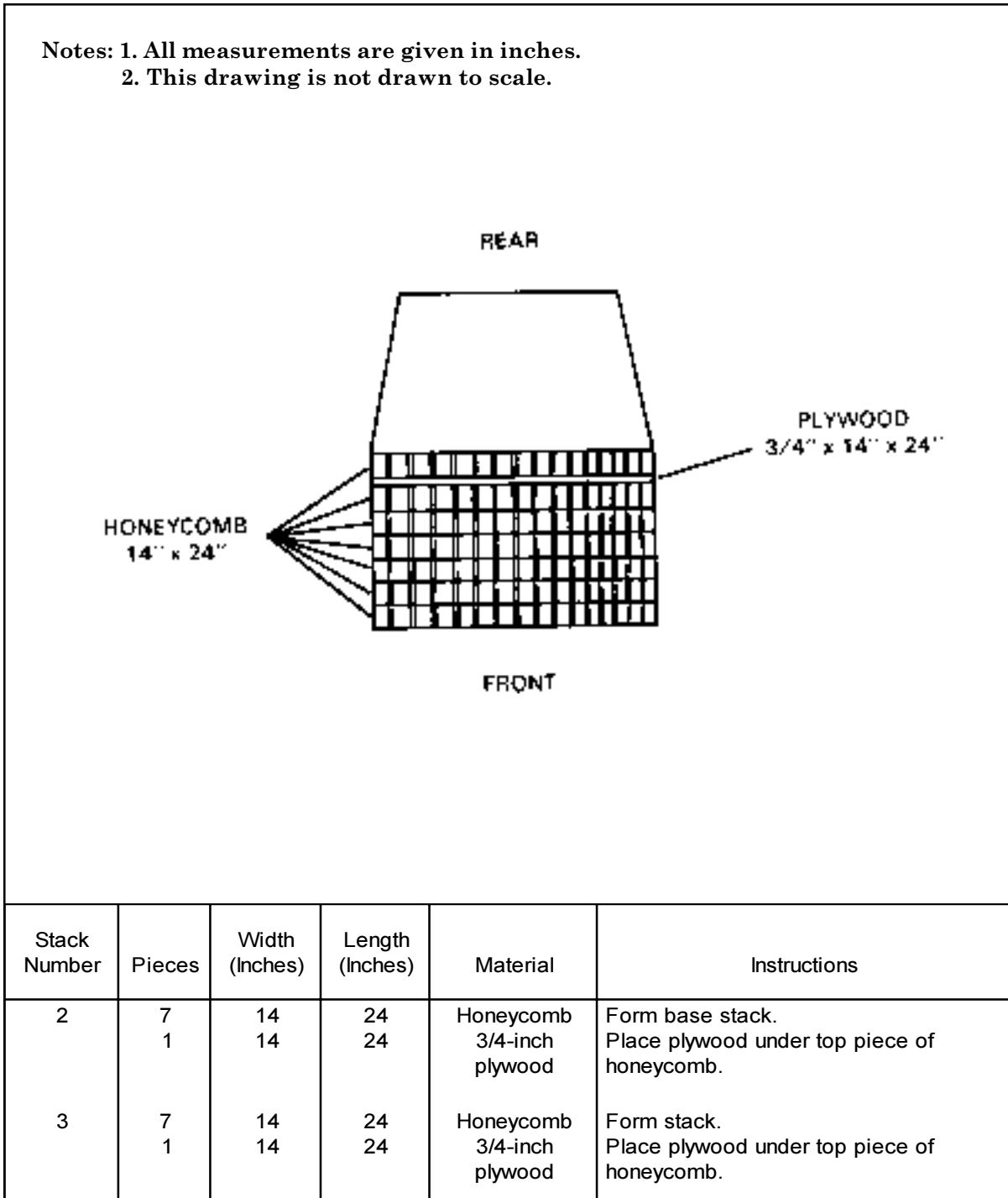

Figure 2-4. Honeycomb Stacks 2 and 3 Prepared

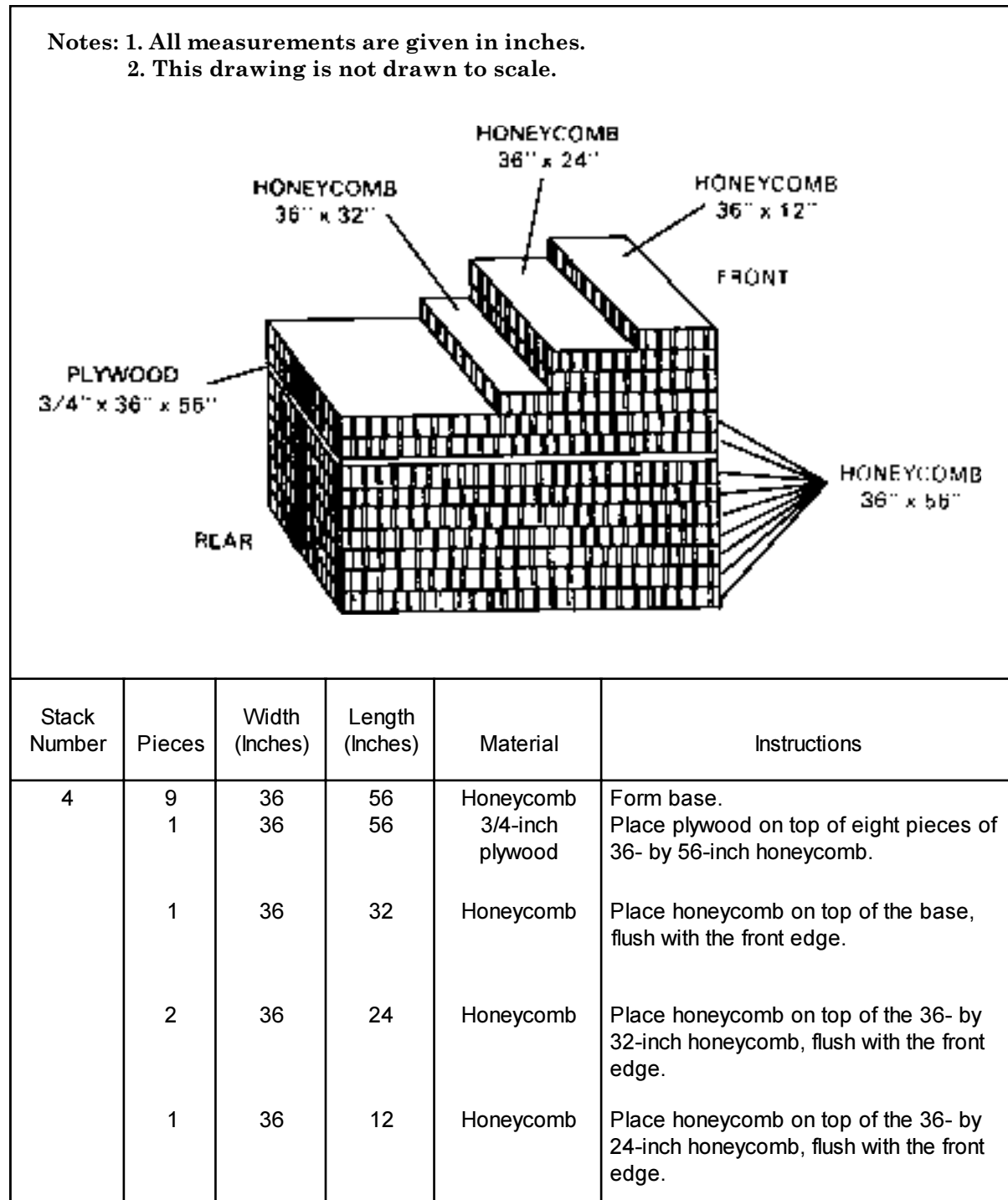
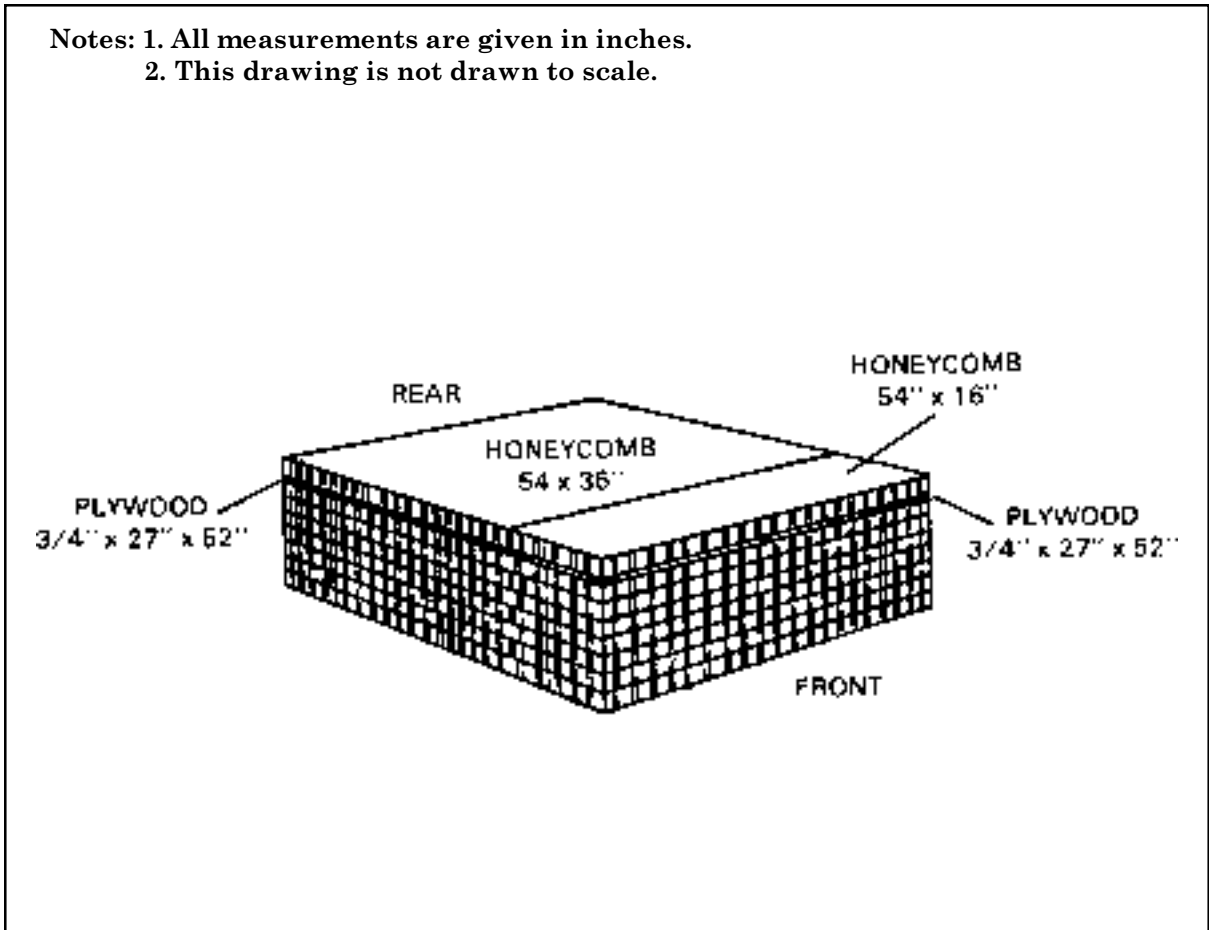

Figure 2-5. Honeycomb Stack 4 Prepared



Stack Number	Pieces	Width (Inches)	Length (Inches)	Material	Instructions
5	8	54	36	Honeycomb	Place honeycomb as part of base. Alternate layers with 54- by 16-inch honeycomb at opposite ends.
	8	54	16	Honeycomb	Place honeycomb as part of base. Alternate it with 54- by 36-inch honeycomb.
	2	27	52	3/4-inch plywood	Place plywood side by side under top layer of base.

Figure 2-6. Honeycomb Stack 5 Prepared

- Notes: 1. All measurements are given in inches.
 2. This drawing is not drawn to scale.

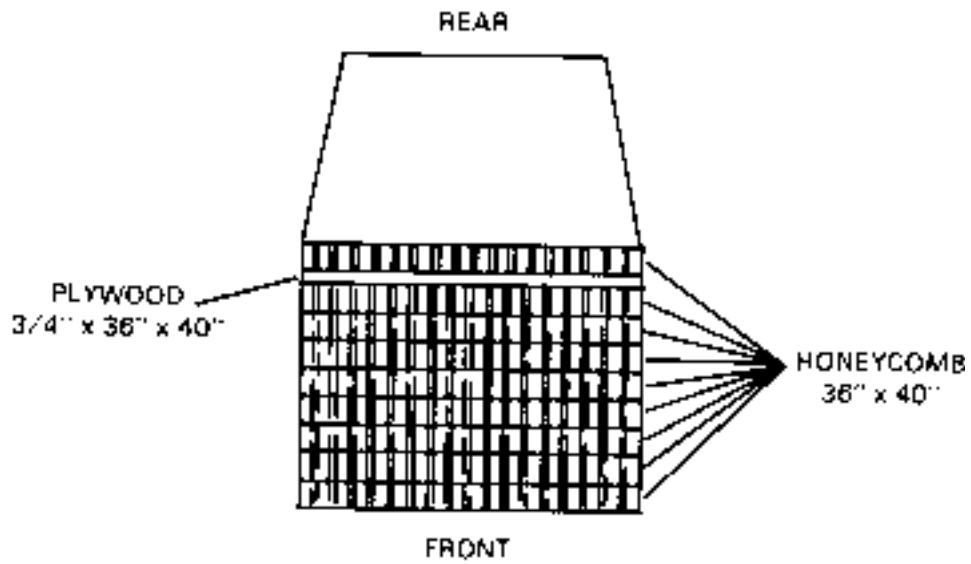

Stack Number	Pieces	Width (Inches)	Length (Inches)	Material	Instructions
6	9	36	40	Honeycomb	Form base.
	1	36	40	3/4-inch plywood	Place plywood under the top piece of honeycomb.

Figure 2-7. Honeycomb Stack 6 Prepared

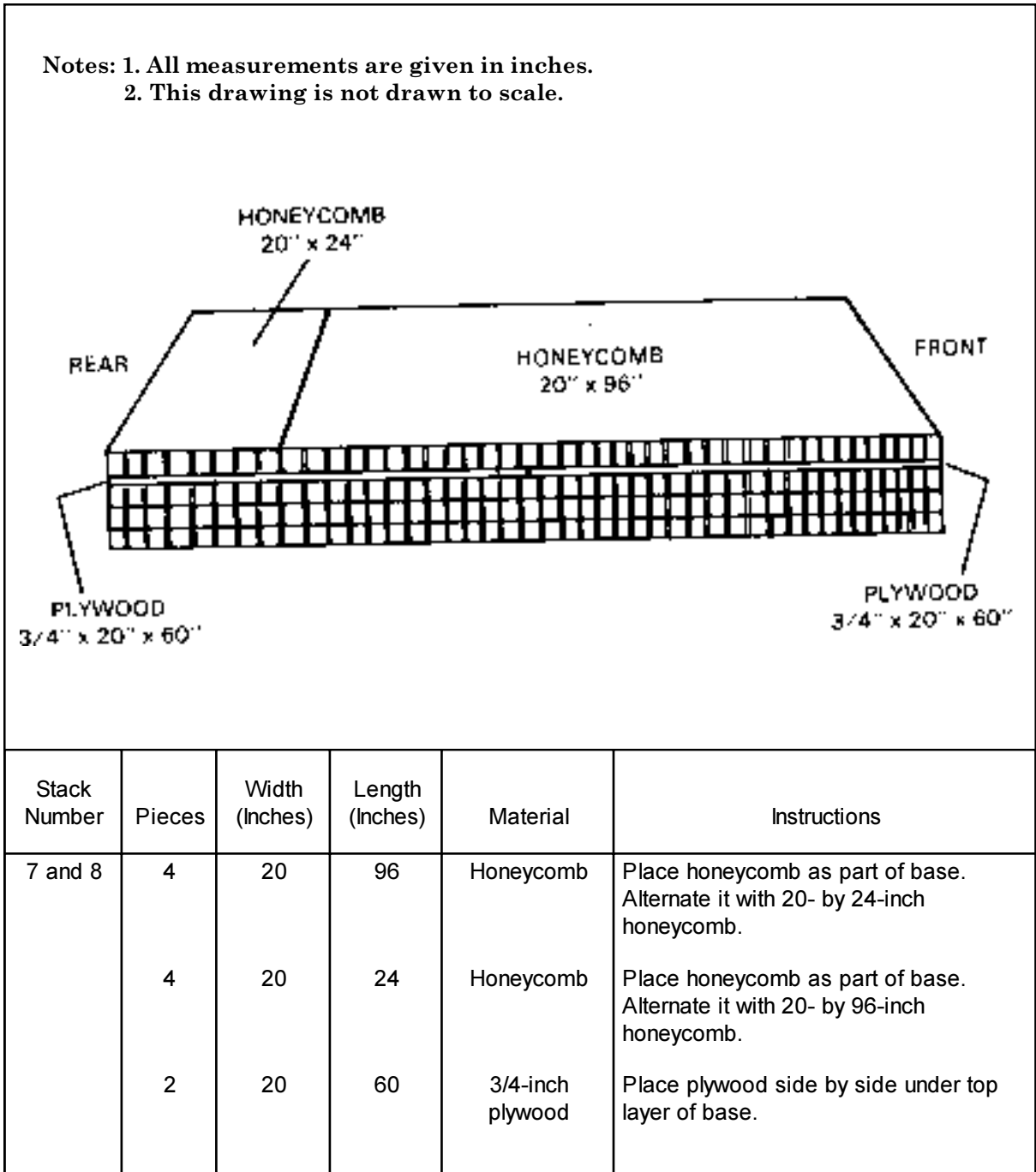

Figure 2-8. Honeycomb Stacks 7 and 8 Prepared

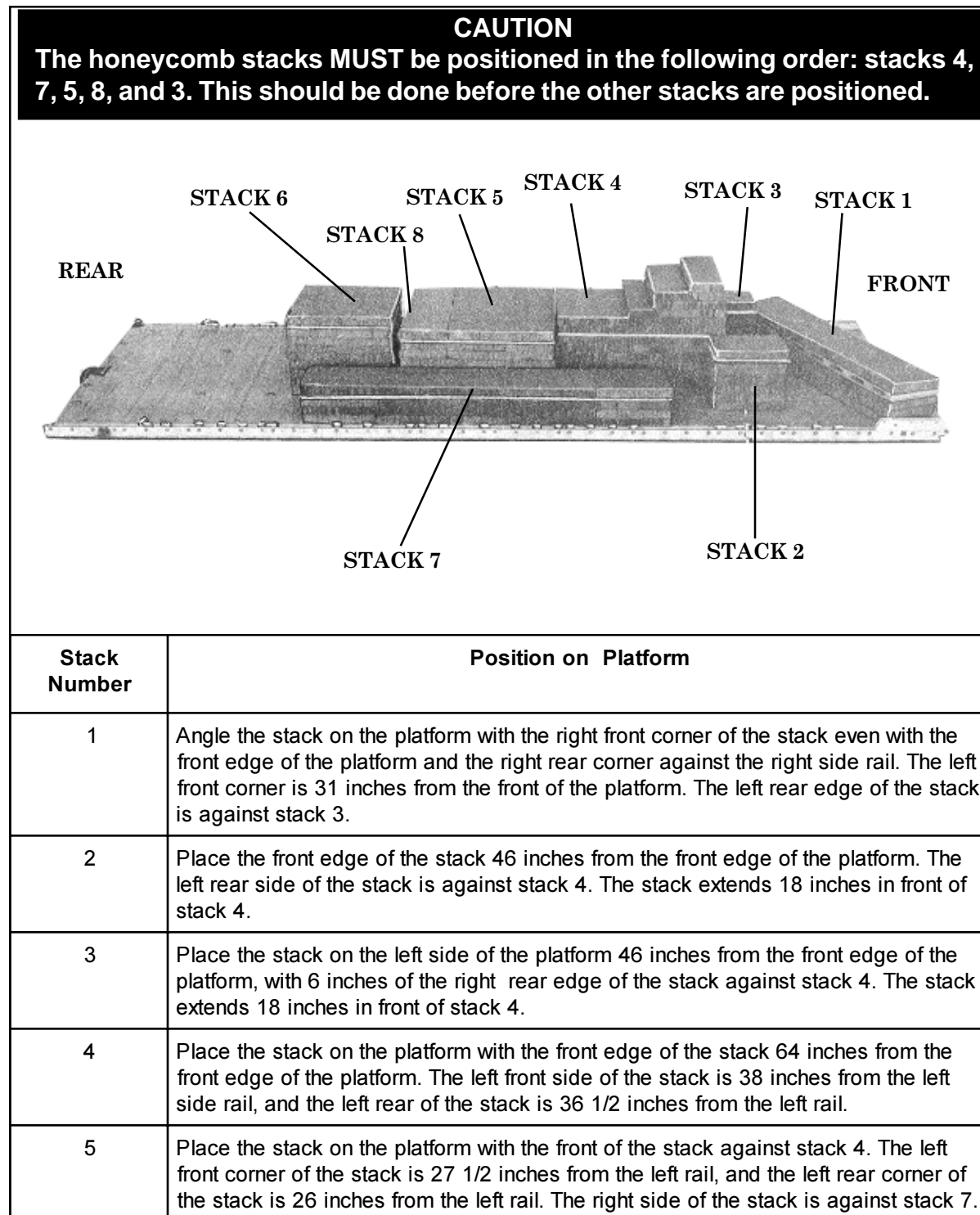
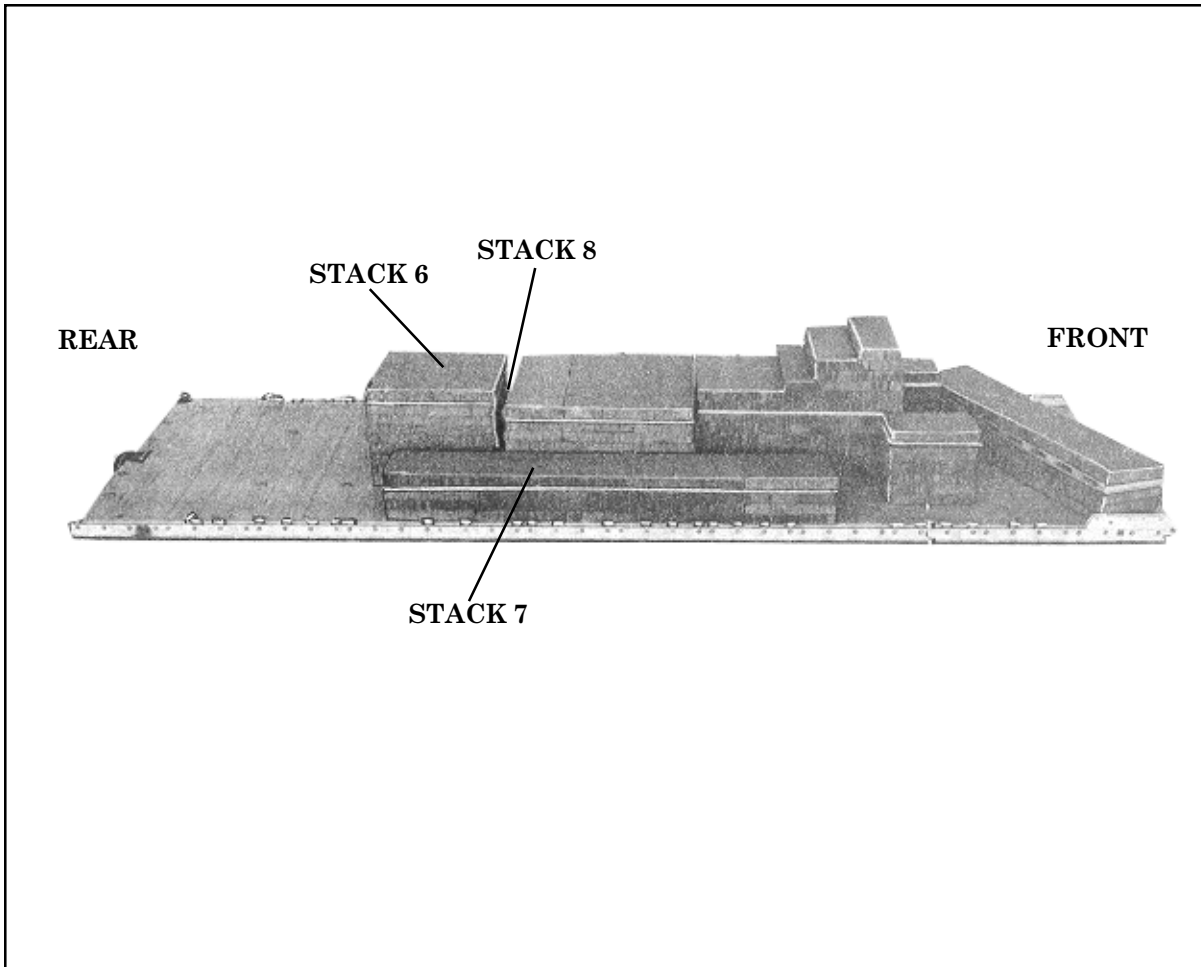

Figure 2-9. Honeycomb Stacks Positioned on Platform



Stack Number	Position on Platform
6	Place the stack on the platform with the front edge of the stack 4 inches from stack 5. The left front corner is 35 inches from the left side rail, and the left rear corner of the stack is 34 inches from the left side rail.
7	Place the right front corner of the stack on the platform 85 inches from the front edge of the platform. The right front corner of the stack is 2 1/2 inches from the right rail, and the right rear corner is 4 1/2 inches from the right rail.
8	Place the left front corner of the stack on the platform 85 inches from the front edge of the platform. The left front corner of the stack is 7 1/2 inches from the left rail, and the left rear corner of the stack is 4 1/2 inches from the left rail.

Figure 2-9. Honeycomb Stacks Positioned on Platform (continued)

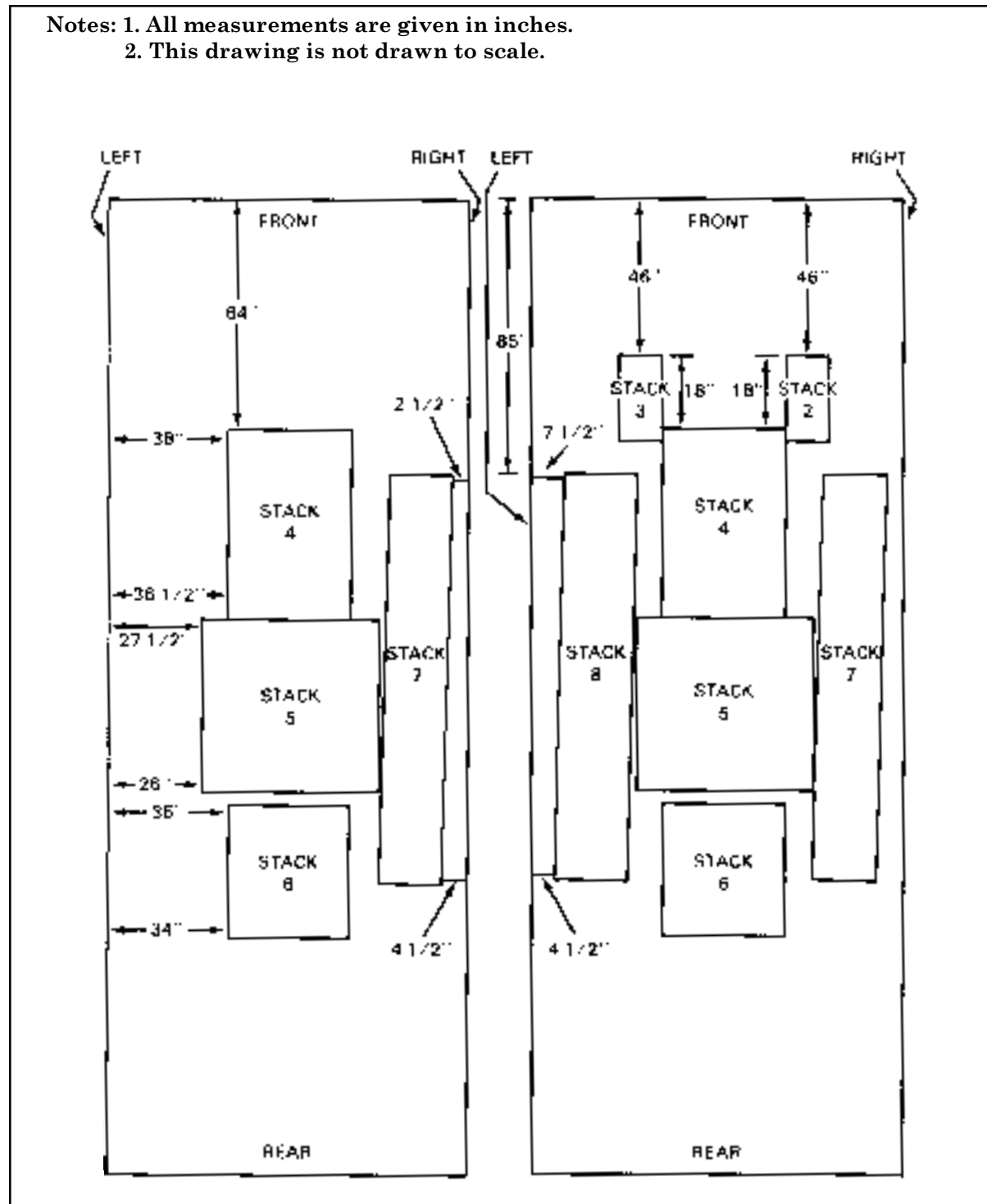

Figure 2-10. Line Drawings of Honeycomb Stacks 2, 3, 4, 5, 6, 7, and 8 Positioned on the Platform

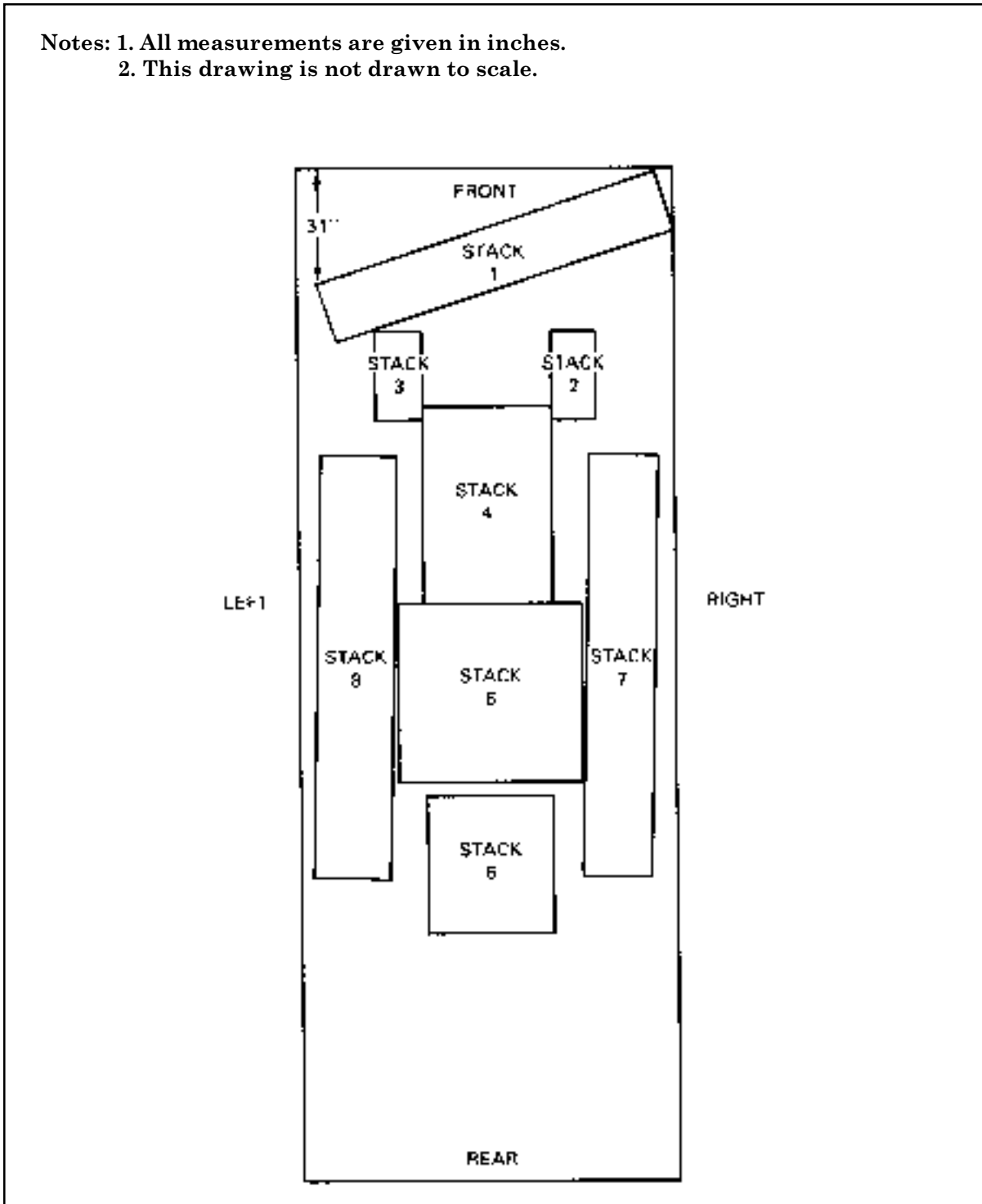

Figure 2-11. Line Drawing of Honeycomb Stacks 1 Through 8 Positioned on the Platform

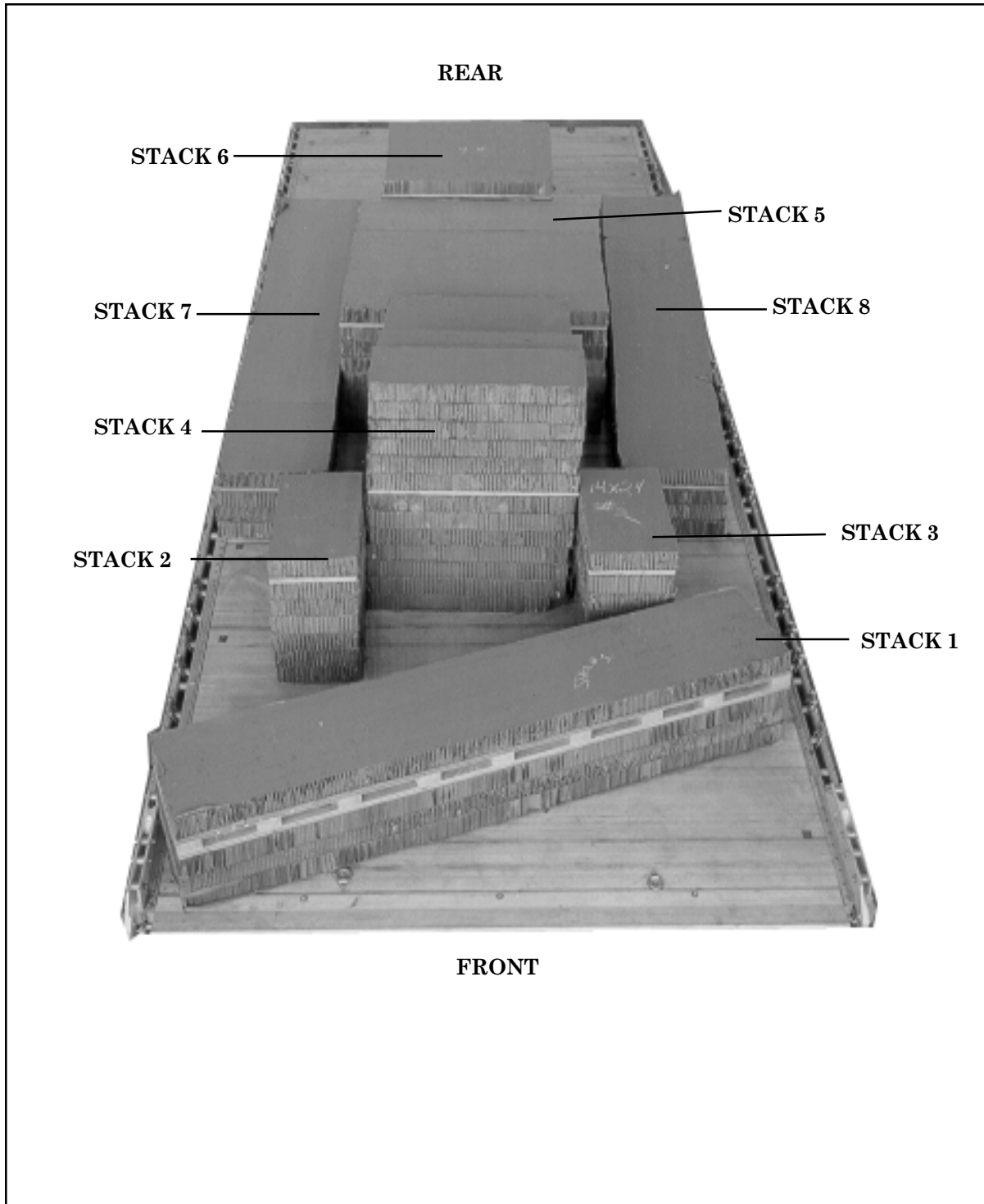

Figure 2-12. Front View of the Honeycomb Stacks Positioned on the Platform

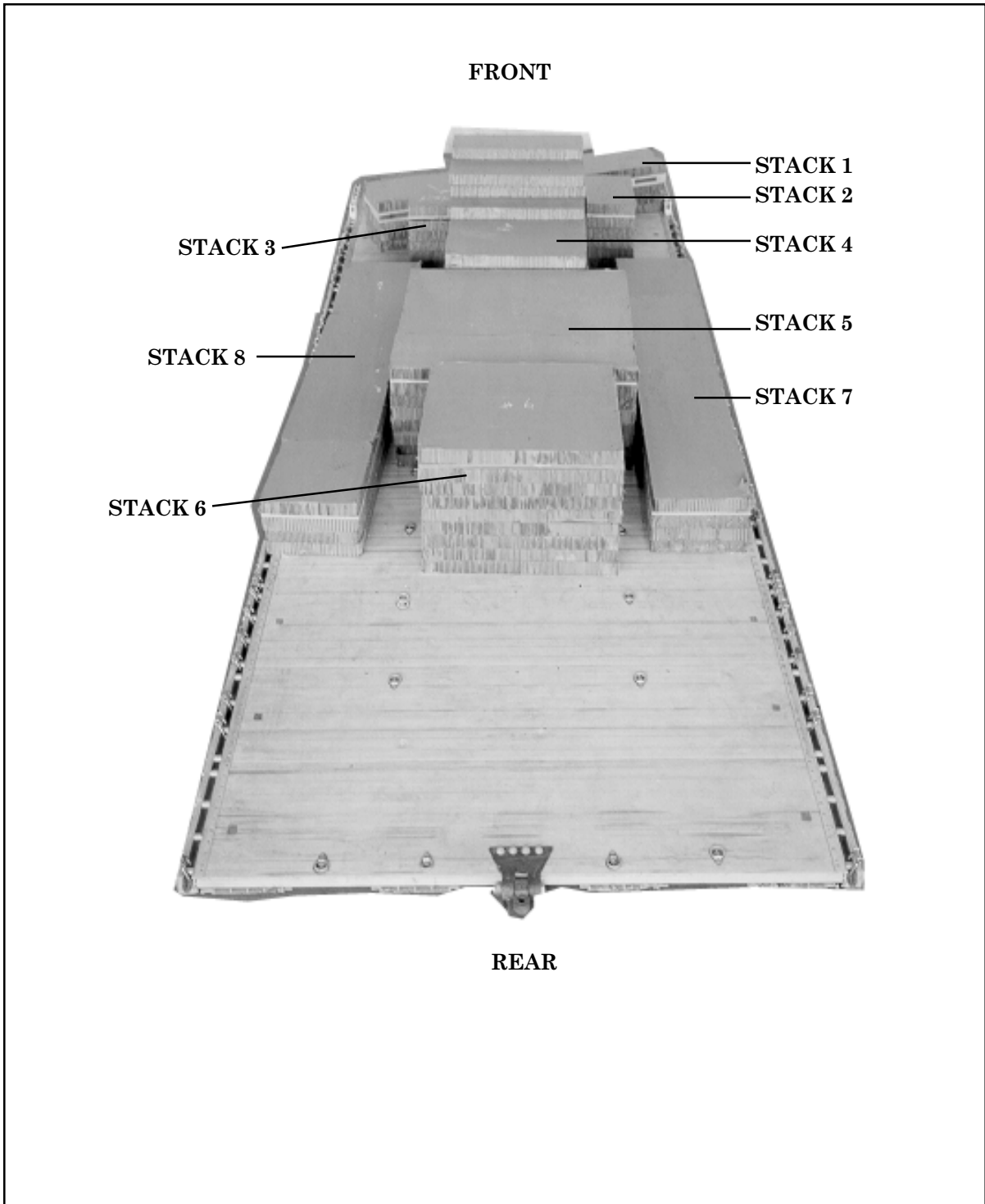

Figure 2-13. Rear View of the Honeycomb Stacks Positioned on the Platform

PREPARING DOZER

2-4. Personnel of the owning unit and rigging unit personnel will prepare the tractor-dozer as described below.

Note: All of the preparations listed below may or may not apply to the tractor-dozer you are rigging. Use only the information that applies to your tractor-dozer. Use the appropriate chapter of this FM for the tractor-dozer you are preparing.

a. Preparation at Unit. The following checks and modifications **MUST** be done by the operator or by qualified maintenance personnel.

(1) Check the batteries before turning the tractor-dozer over to the rigging unit. Cover all wet cell batteries in service with plastic or nonflammable material.

(2) Check the fuel level before the tractor-dozer is turned over to the rigging unit. Make sure the fuel tank is not more than 3/4 full or not less than 1/2 full.

(3) Remove the ROPS and the ROPS mounting brackets attached to the tractor-dozer. Remove the nose wheel and bracket and the pivot bracket before the tractor-dozer is delivered to the rigging site.

b. Preparation at Rigging Site. The following preparations are made at the rigging site.

(1) Check the fuel level. Make sure the fuel tank is not more than 3/4 full or not less than 1/2 full.

(2) Pad the front ROPS mounting brackets with 1/2-inch felt, and tape the felt in place.

(3) Prepare the tractor-dozer as shown in Figure 2-14.

Note: A qualified tractor-dozer operator must be available at the rigging site when the tractor-dozer is rigged.

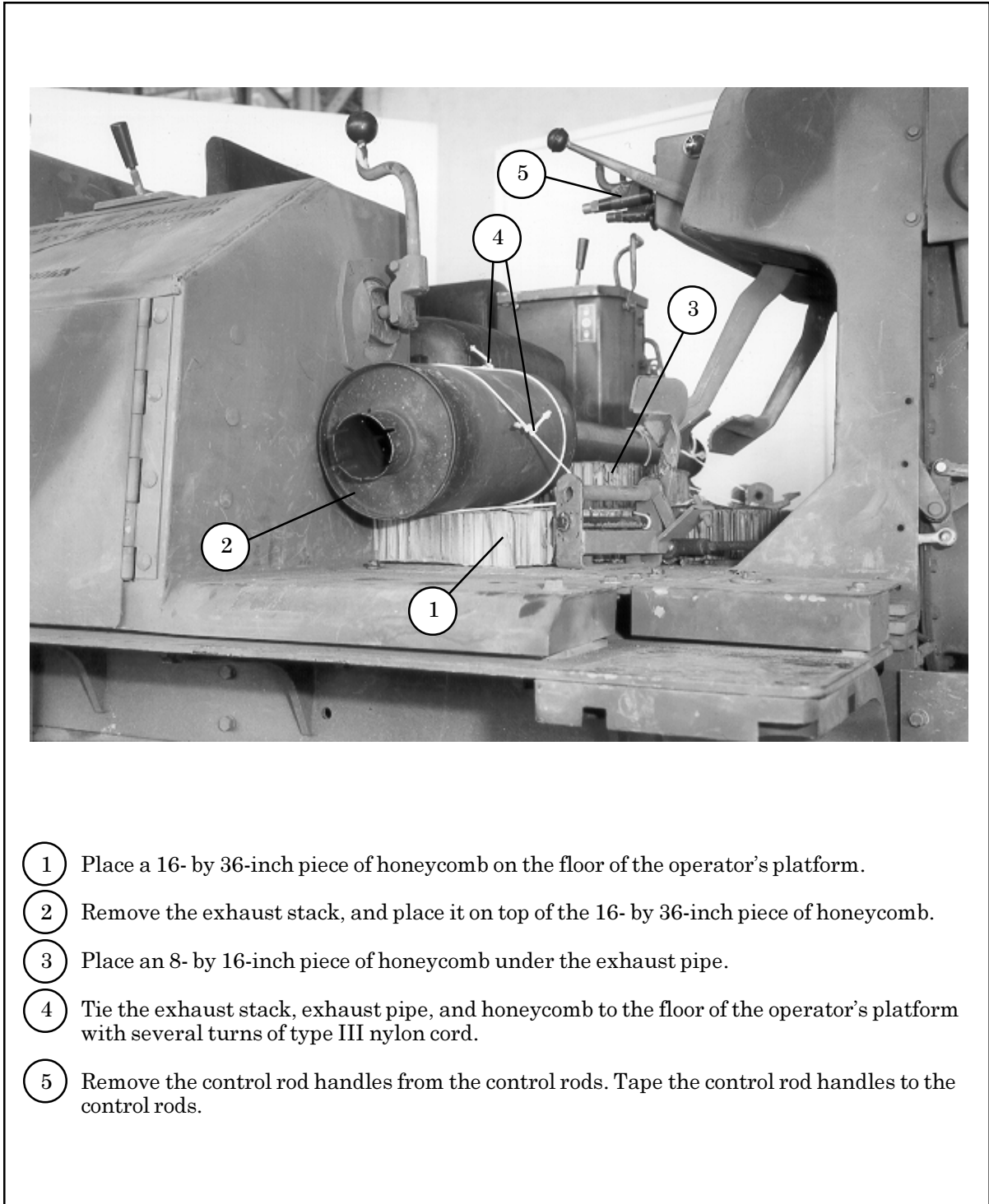

Figure 2-14. Tractor-Dozer Prepared

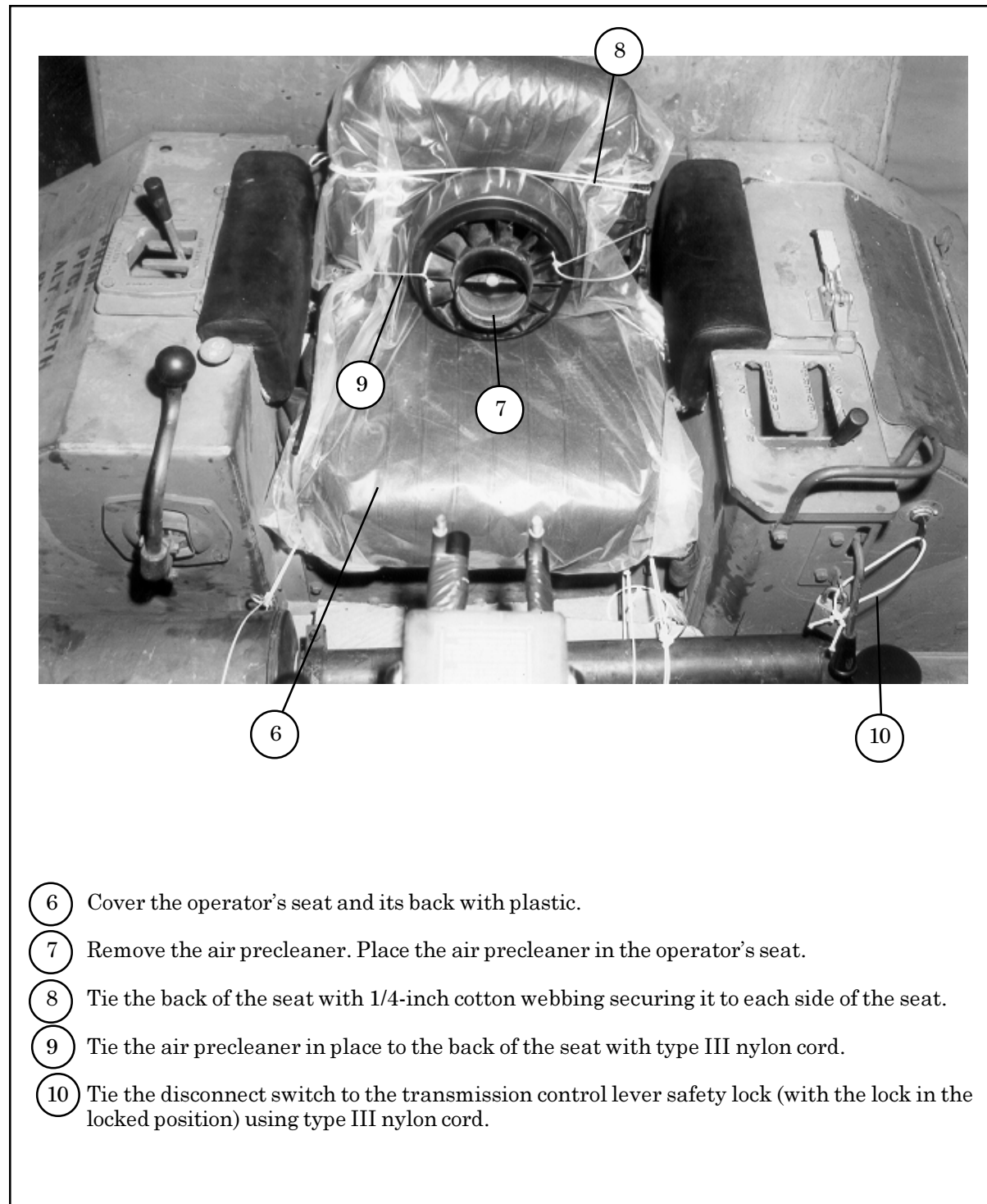
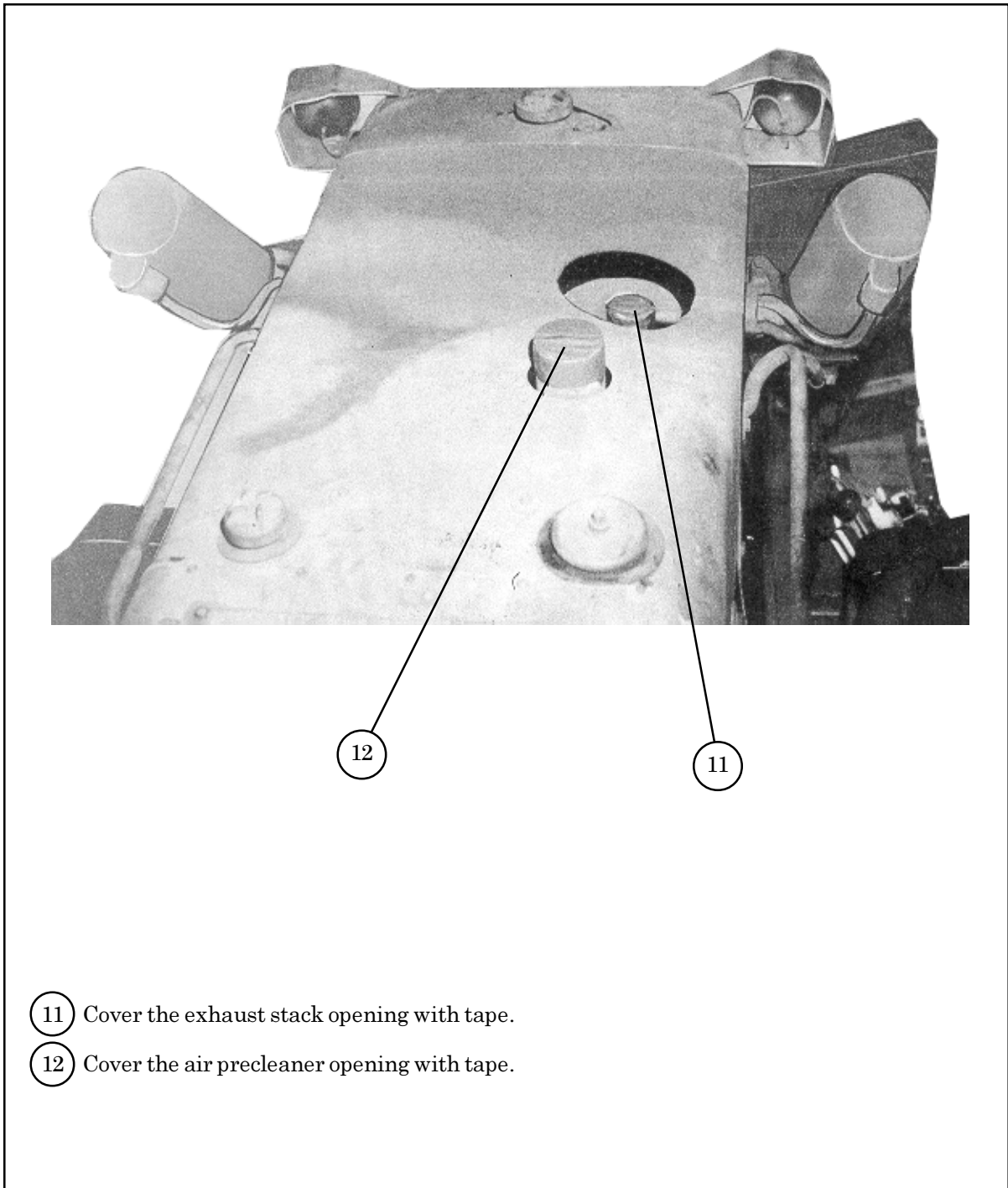

Figure 2-14. Tractor-Dozer Prepared (Continued)



- ①① Cover the exhaust stack opening with tape.
- ①② Cover the air precleaner opening with tape.

Figure 2-14. Tractor-Dozer Prepared (Continued)

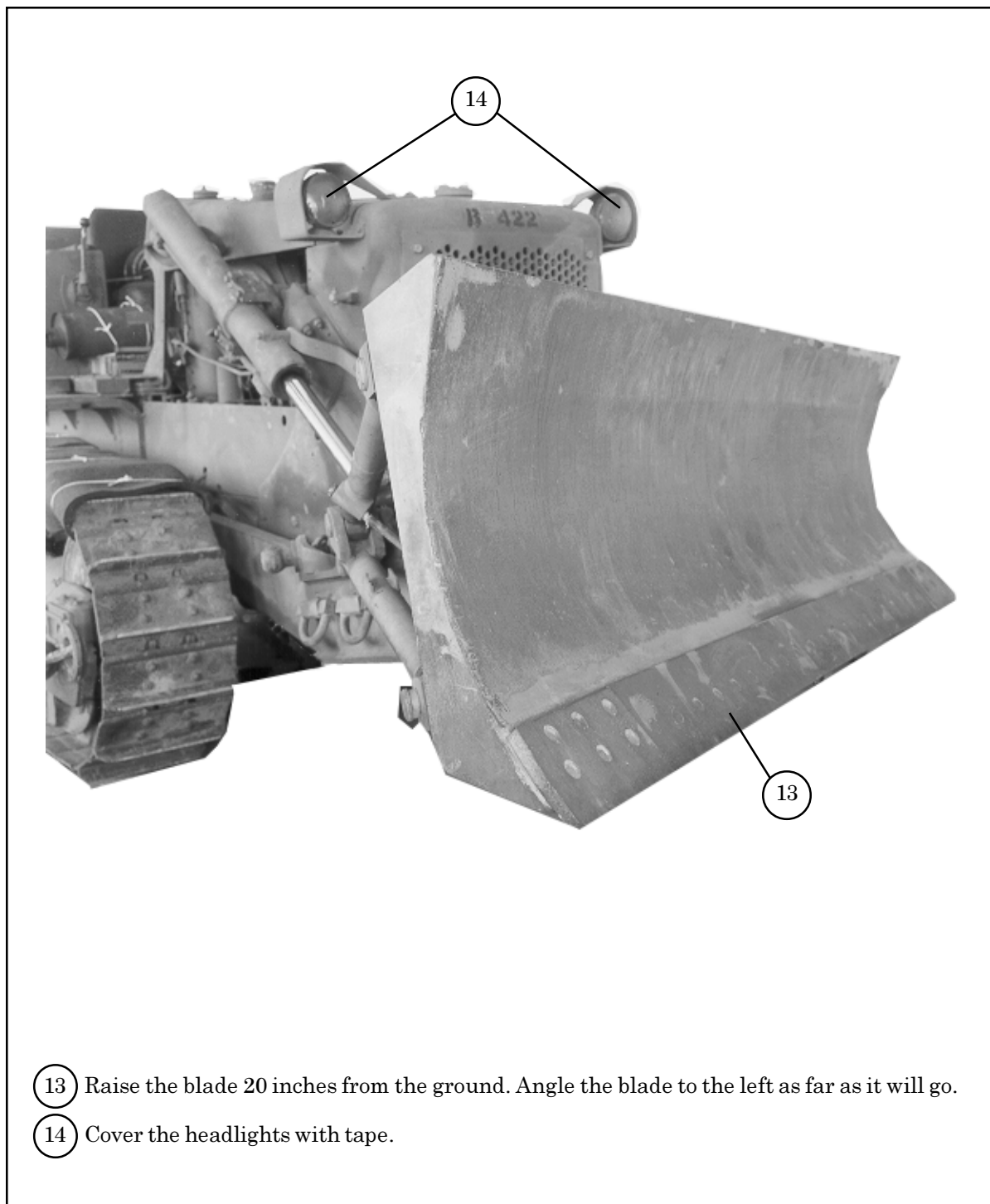

Figure 2-14. Tractor-Dozer Prepared (Continued)

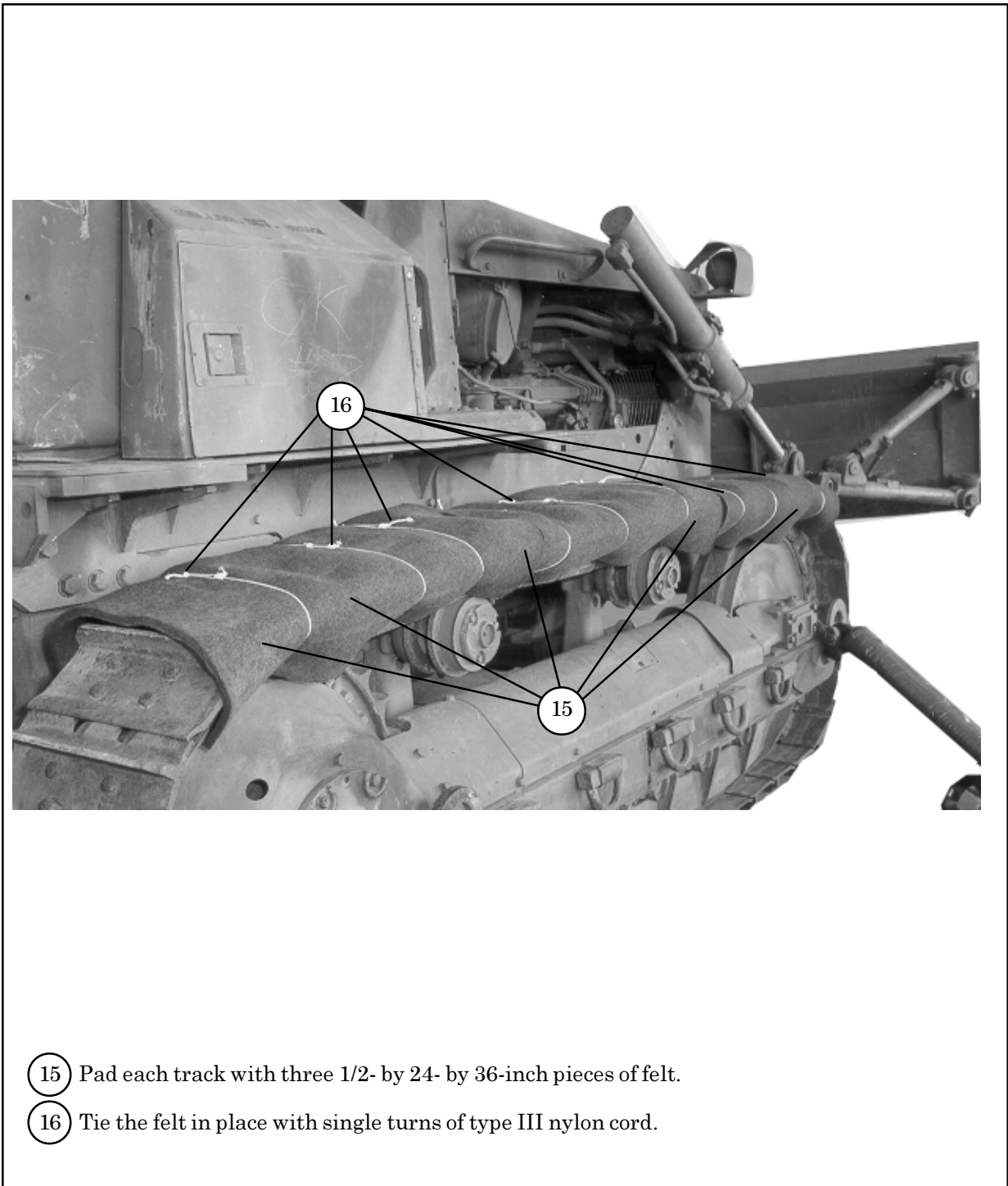

Figure 2-14. Tractor-Dozer Prepared (Continued)

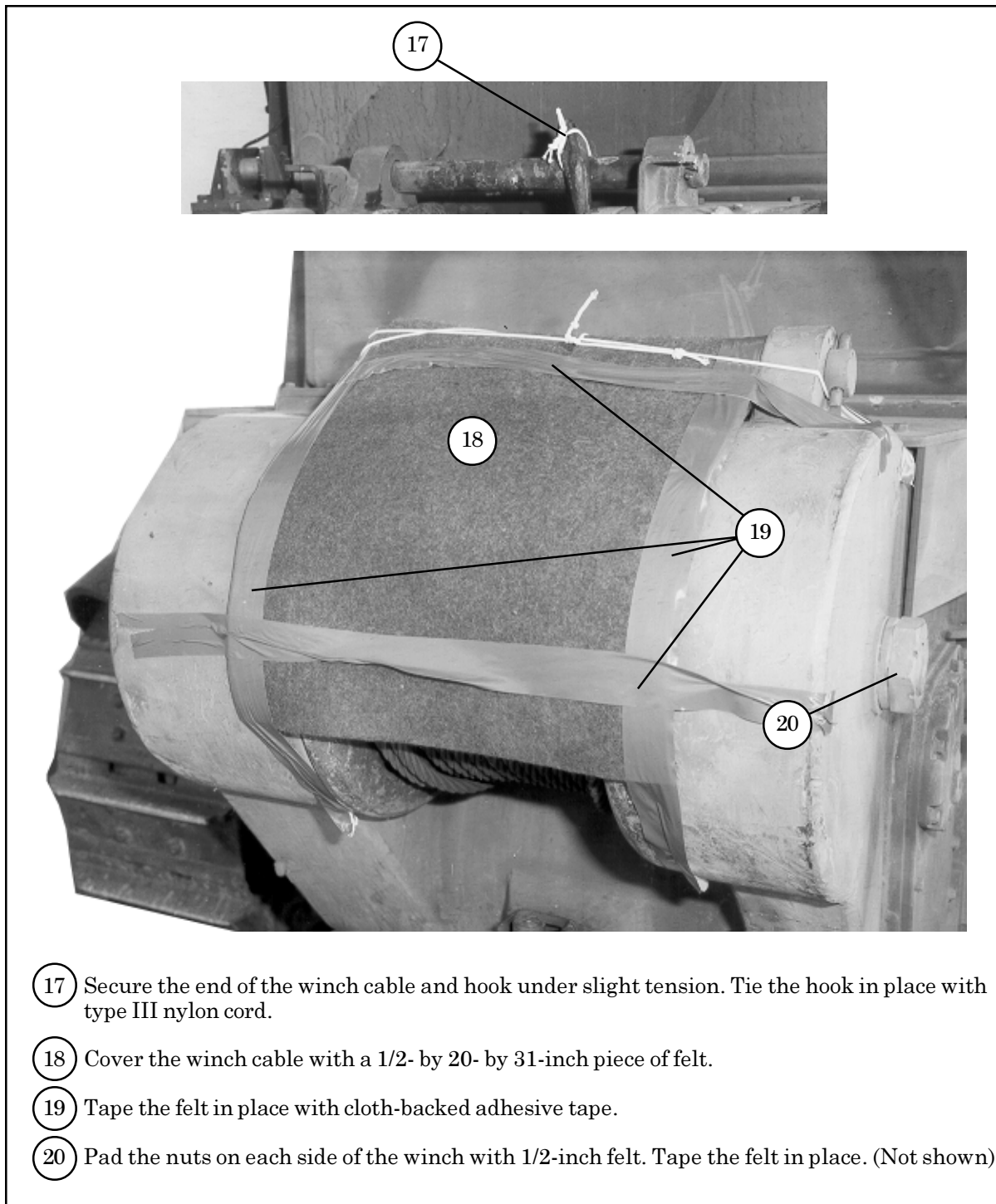
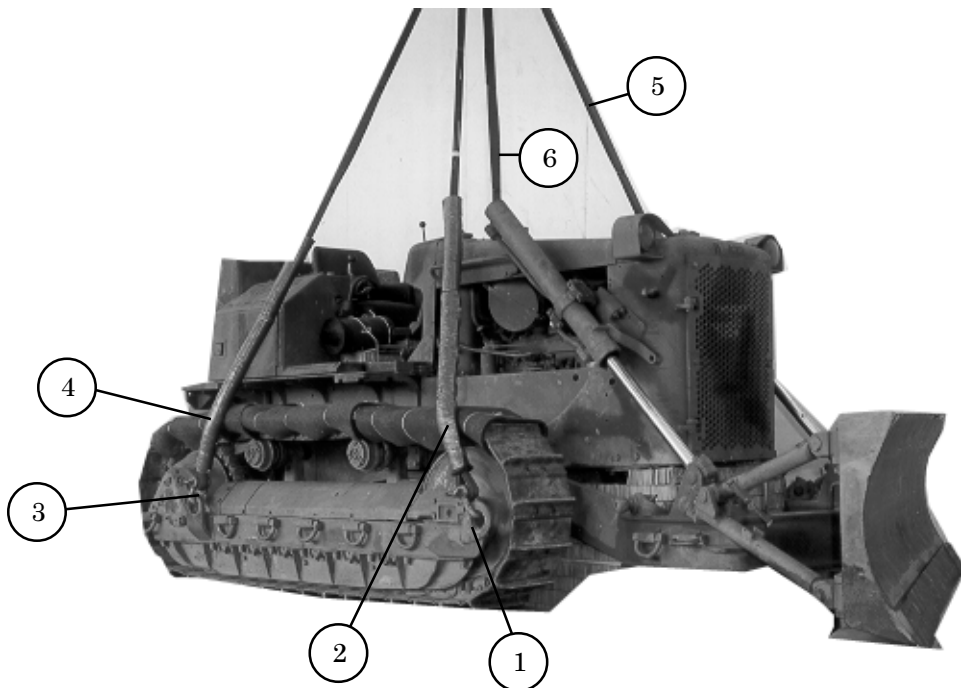

Figure 2-14. Tractor-Dozer Prepared (Continued)

INSTALLING SUSPENSION SLINGS

2-5. Install four 12-foot (4-loop), type XXVI nylon webbing slings for suspension slings as outlined in Figure 2-15.

Note: Attach a large screw-pin clevis to each lifting point for suspension purposes.



- ① Install a sling on the right front lifting point with a large screw-pin clevis and spacer.
- ② Pad the sling with a 1/2- by 12- by 36-inch piece of felt. Adjust the felt on the sling as necessary to make sure the sling does not touch the track.
- ③ Install a sling on the right rear lifting point with a large screw-pin clevis and spacer.
- ④ Pad the sling with a 1/2- by 12- by 36-inch piece of felt. Adjust the felt on the sling as necessary to make sure the sling does not touch the track.
- ⑤ Install a sling on the left front lifting point adapting the procedures as described in steps 1 and 2 above.
- ⑥ Install a sling on the left rear lifting point adapting the procedures as described in steps 3 and 4 above.

Figure 2-15. Suspension Slings Installed

LIFTING AND POSITIONING DOZER

2-6. Lift the dozer using the slings and position it on the honeycomb stacks as shown in Figure 2-16.

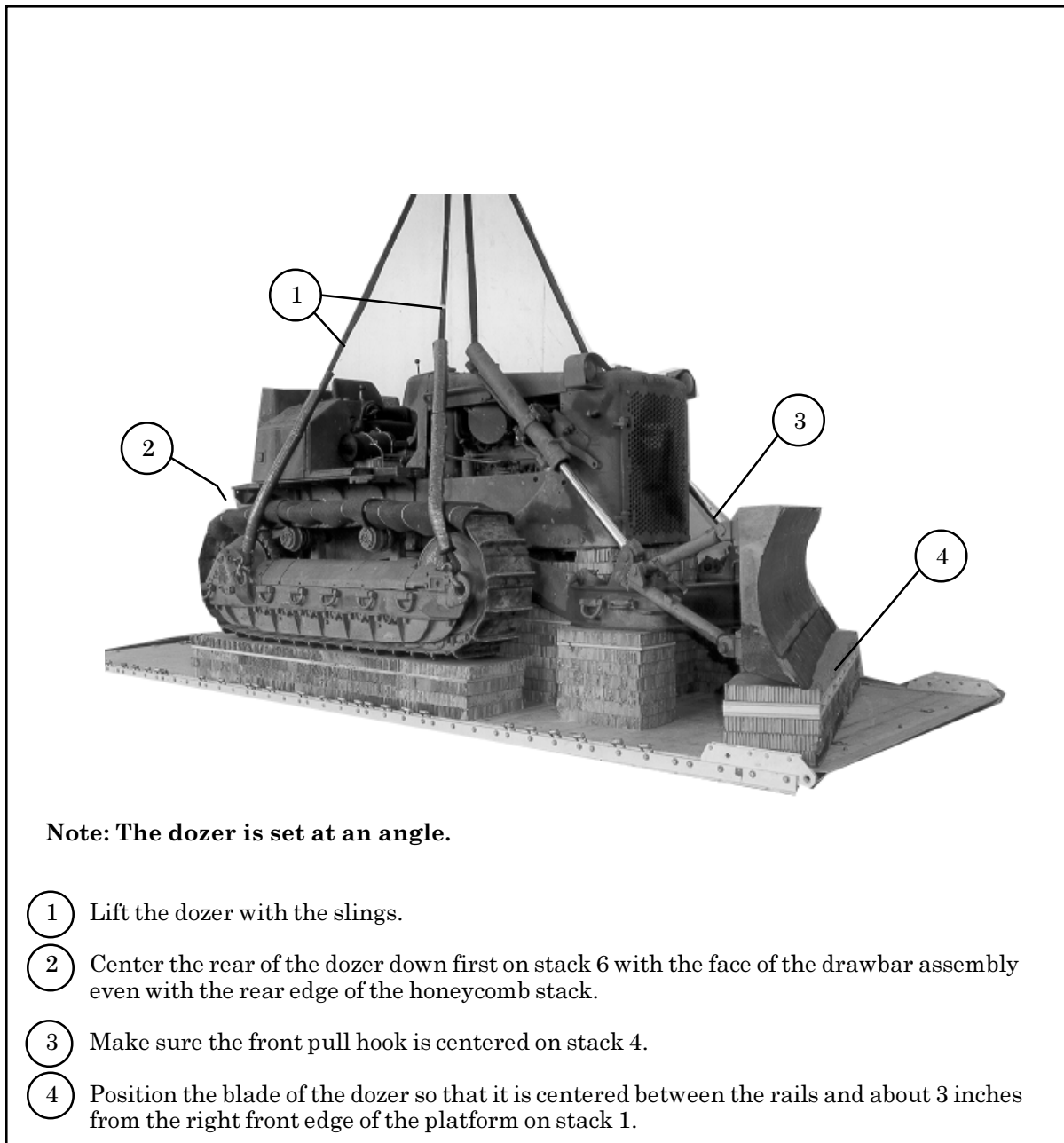

Figure 2-16. Dozer Positioned

LASHING DOZER

2-7. Lash the dozer to the platform with fifty-two 15-foot tiedown assemblies according to FM 4-20.102/NAVSEA SS400-AB-MMO-010/TO 13C7-1-5 and as shown in Figures 2-17 through 2-21.

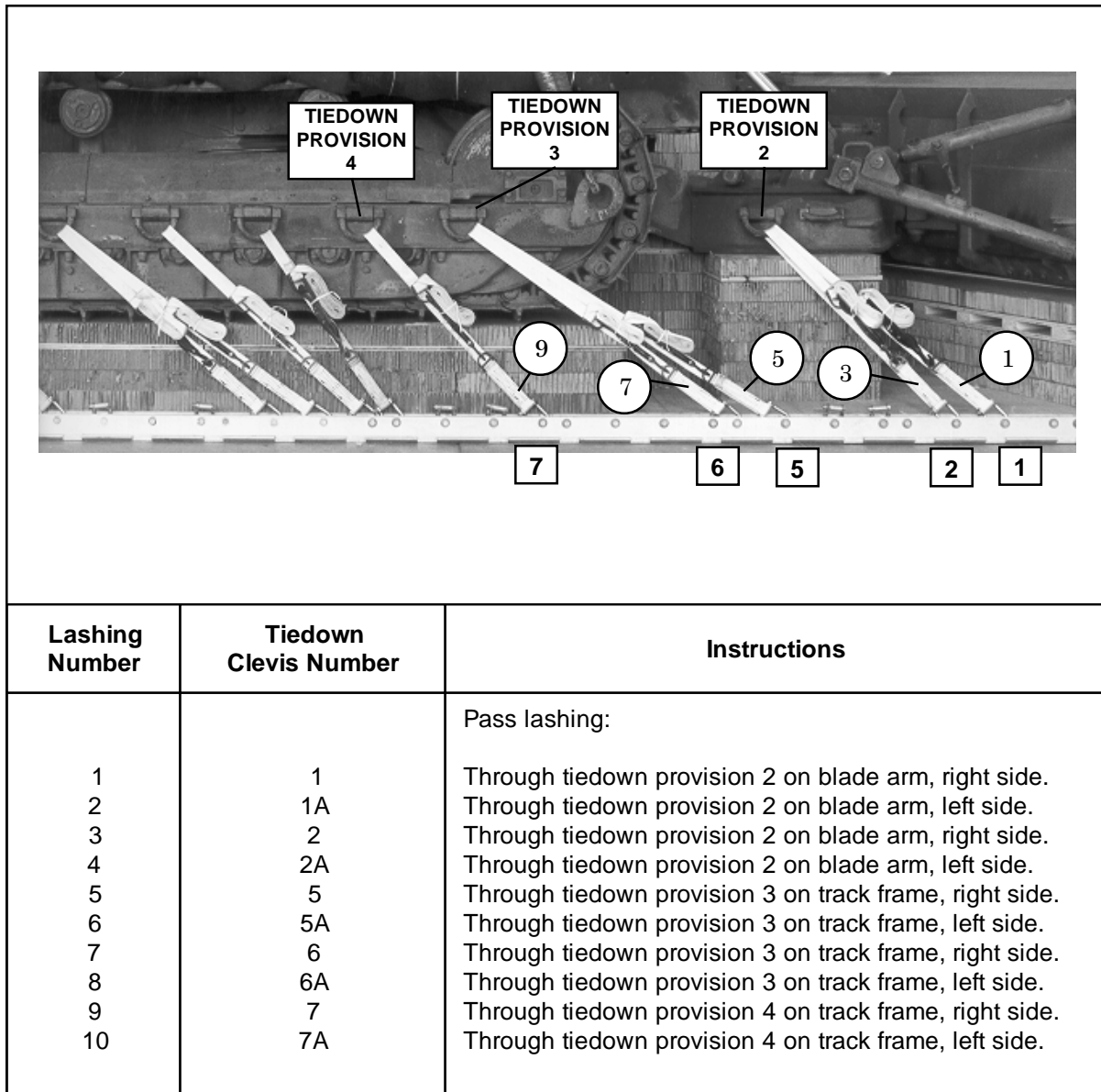

Figure 2-17. Lashings 1 through 10 Installed

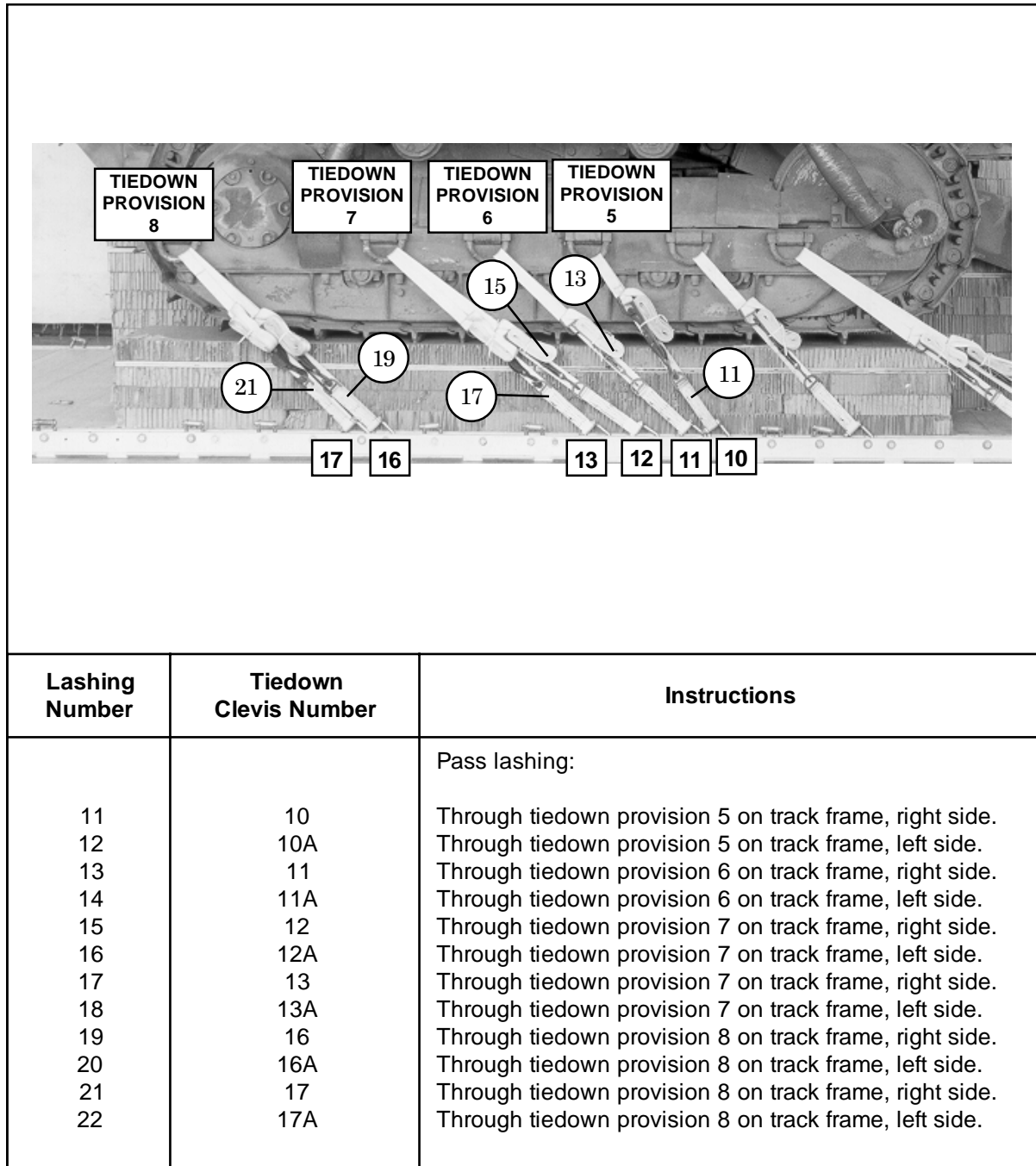
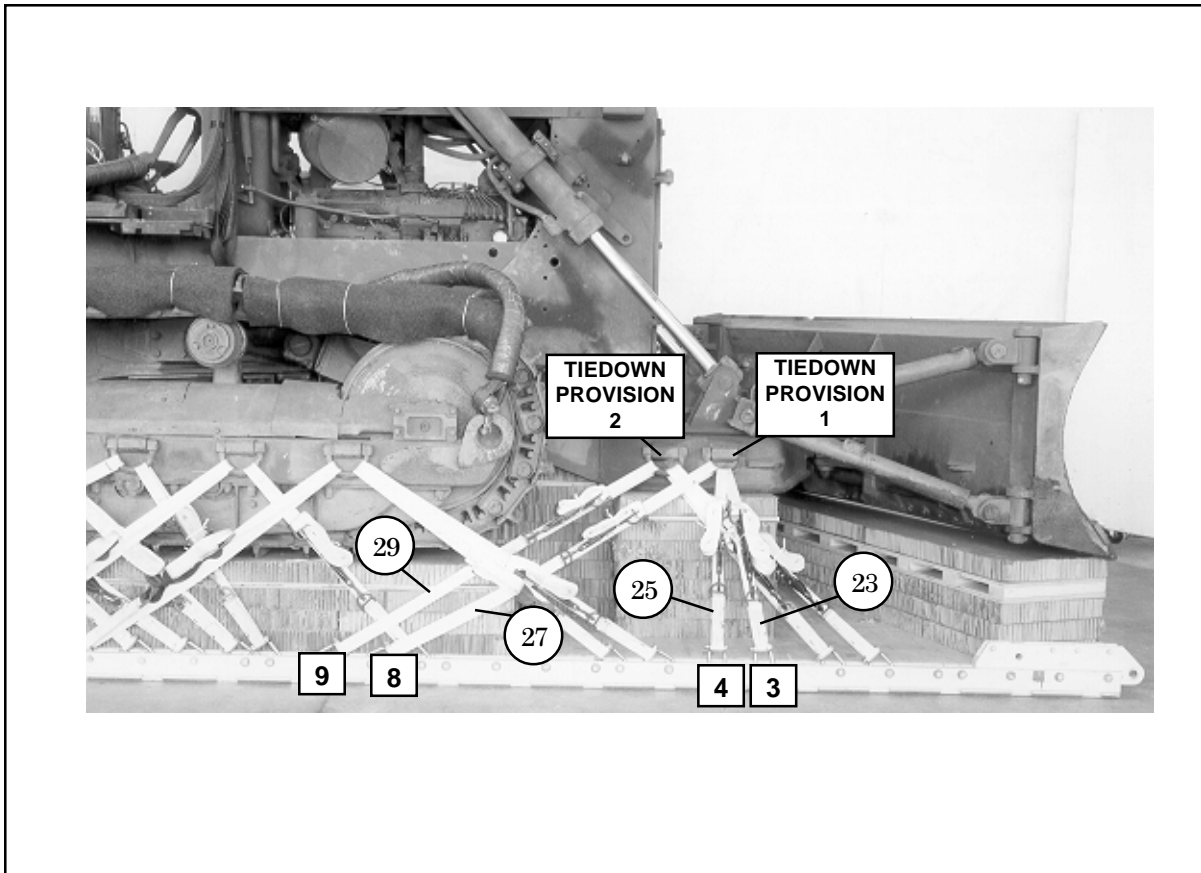

Figure 2-18. Lashings 11 through 22 Installed



Lashing Number	Tiedown Clevis Number	Instructions
<p>23</p> <p>24</p> <p>25</p> <p>26</p> <p>27</p> <p>28</p> <p>29</p> <p>30</p>	<p>3</p> <p>3A</p> <p>4</p> <p>4A</p> <p>8</p> <p>8A</p> <p>9</p> <p>9A</p>	<p>Pass lashing:</p> <p>Through tiedown provision 1 on blade arm, right side.</p> <p>Through tiedown provision 1 on blade arm, left side.</p> <p>Through tiedown provision 1 on blade arm, right side.</p> <p>Through tiedown provision 1 on blade arm, left side.</p> <p>Through tiedown provision 1 on blade arm, right side.</p> <p>Through tiedown provision 1 on blade arm, left side.</p> <p>Through tiedown provision 1 on blade arm, right side.</p> <p>Through tiedown provision 2 on blade arm, right side.</p> <p>Through tiedown provision 2 on blade arm, left side.</p>

Figure 2-19. Lashings 23 through 30 Installed

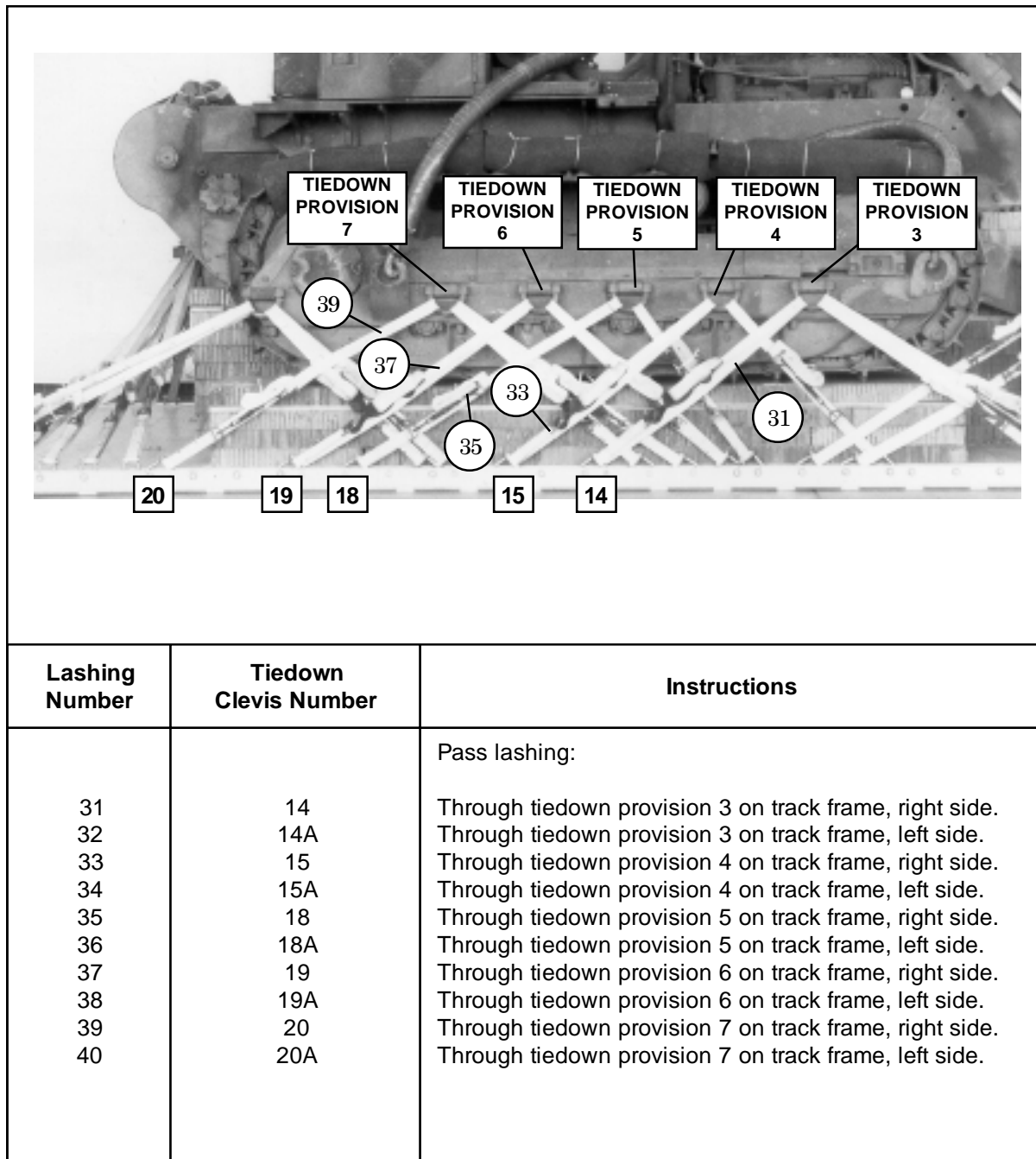
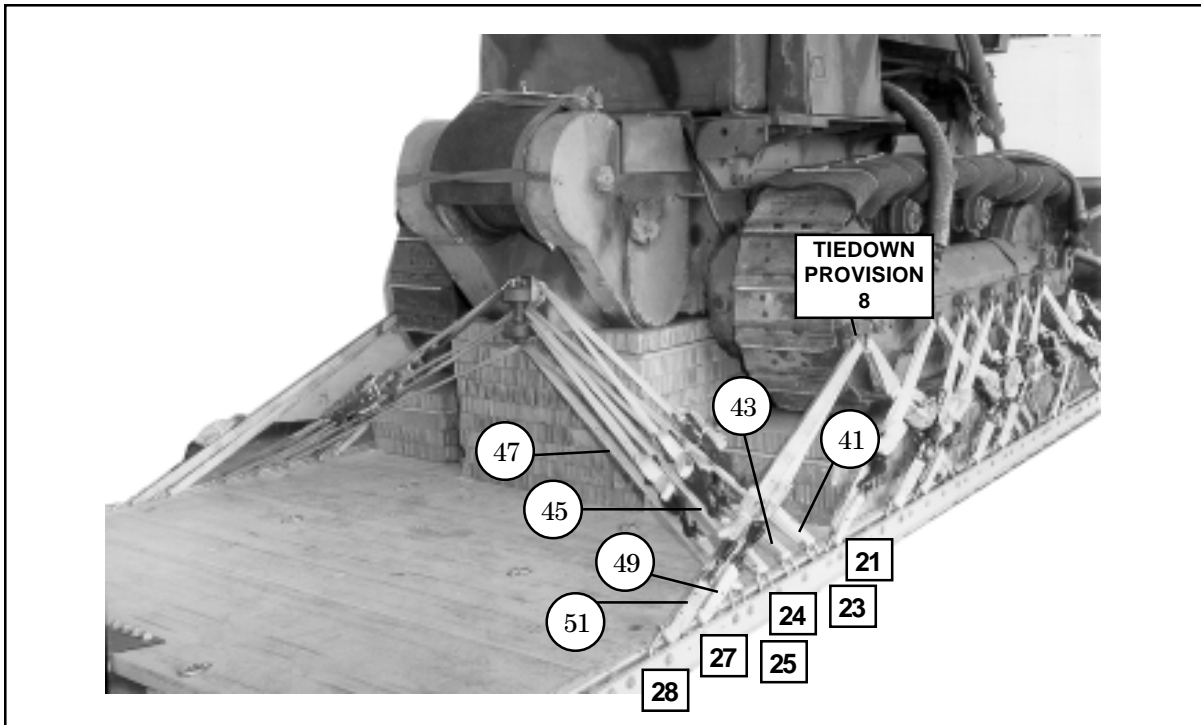

Figure 2-20. Lashings 31 through 40 Installed



Lashing Number	Tiedown Clevis Number	Instructions
41	21	Pass lashing: Around top lug of drawbar bracket.
42	21A	Around top lug of drawbar bracket.
43	23	Around bottom lug of drawbar bracket.
44	23A	Around bottom lug of drawbar bracket.
45	24	Around top lug of drawbar bracket.
46	24A	Around top lug of drawbar bracket.
47	25	Around bottom lug of drawbar bracket.
48	25A	Around bottom lug of drawbar bracket.
49	27	Through tiedown provision 8 on track frame, right side.
50	27A	Through tiedown provision 8 on track frame, left side.
51	28	Through tiedown provision 8 on track frame, right side.
52	28A	Through tiedown provision 8 on track frame, left side.

Figure 2-21. Lashings 41 through 52 Installed

PADDING AND SECURING HYDRAULIC CYLINDERS

2-8. Pad and secure the hydraulic cylinders as shown in Figure 2-22.

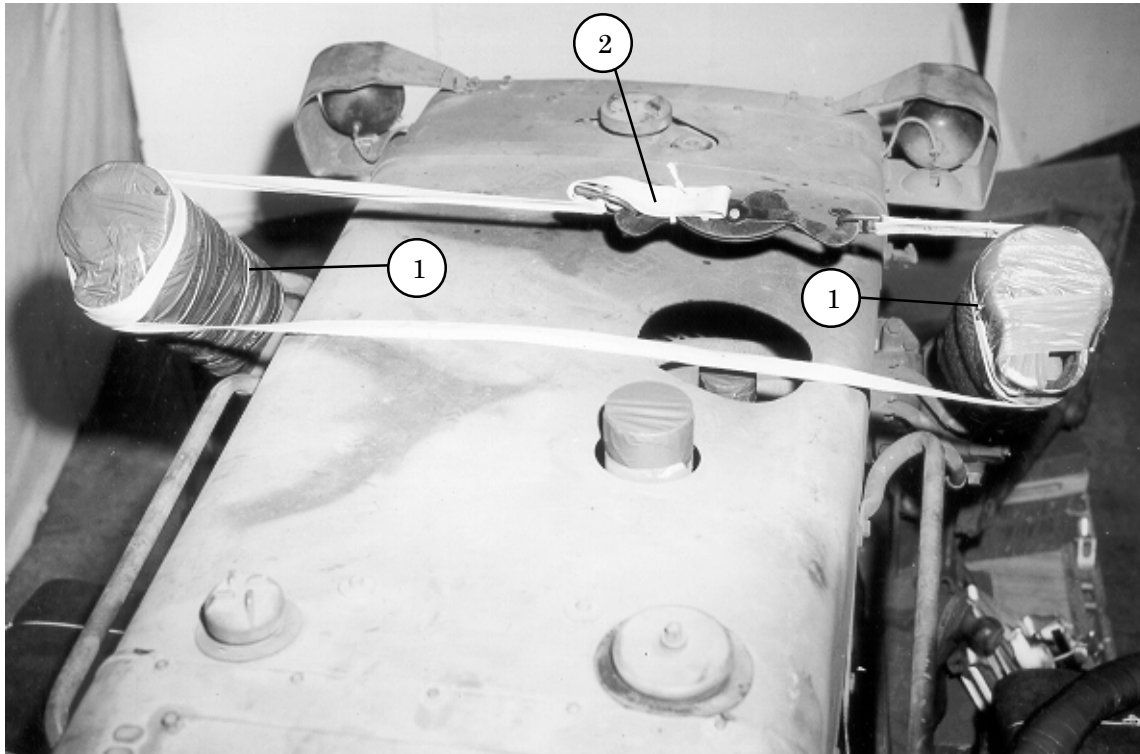

- ① Pad the top part of each hydraulic cylinder with 1/2- by 18- by 24-inch piece of felt, and tape the felt in place. Tie the taped felt to each hydraulic cylinder with type III nylon cord.
- ② Pass one end of a 15-foot tiedown strap around one cylinder and then around the other cylinder. Secure the ends of the strap together according to FM 4-20.102/NAVSEA SS400-AB-MMO-010/TO 13C7-1-5.

Figure 2-22. Hydraulic Cylinders Padded and Secured

INSTALLING LOAD COVER

2-9. Install the load cover as shown in Figure 2-23.

INSTALLING DEADMAN'S TIE

NOTICE OF EXCEPTION

The procedures in this paragraph are different from those in FM 4-20.102/NAVSEA SS400-AB-MNO-010/TO 13C7-1-5. The deadman's tie is installed even with the top of the load. An exception to FM 4-20.102/NAVSEA SS400-AB-MNO-010/TO 13C7-1-5 is granted.

2-10. Install the deadman's tie as shown in Figure 2-23.

SAFETY TIEING SUSPENSION SLINGS

2-11. Install a safety tie on the suspension slings as shown in Figure 2-23.

SAFETY TIEING LOAD SPREADER

2-12. Install a safety tie on the load spreader in honeycomb stack 1 as shown in Figure 2-23.

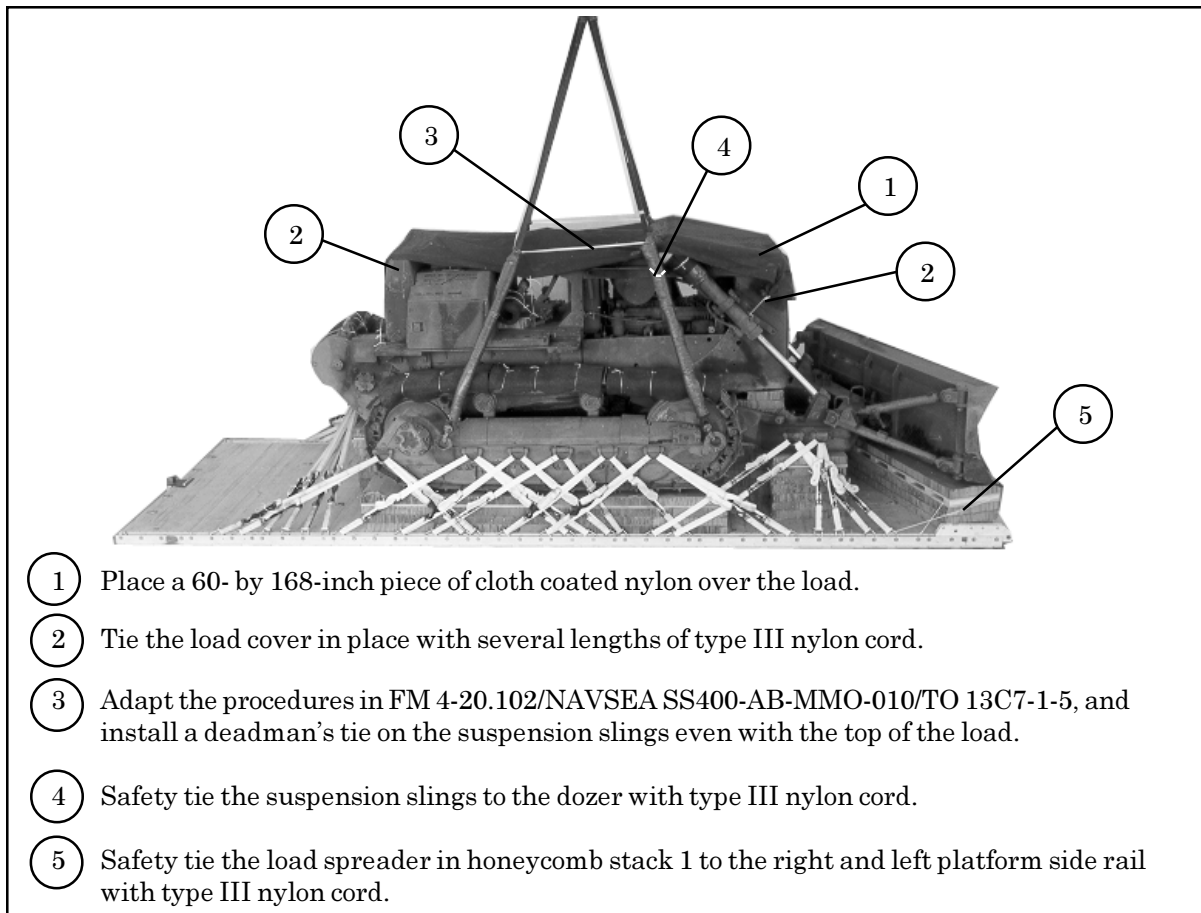

Figure 2-23. Load Cover, Deadman's Tie, and Safety Ties Installed

STOWING CARGO PARACHUTES

2-13. Build a parachute stowage platform, and stow the cargo parachutes as described below.

a. Building Stowage Platform. Build the stowage platform using the dimensions in Figure 2-24.

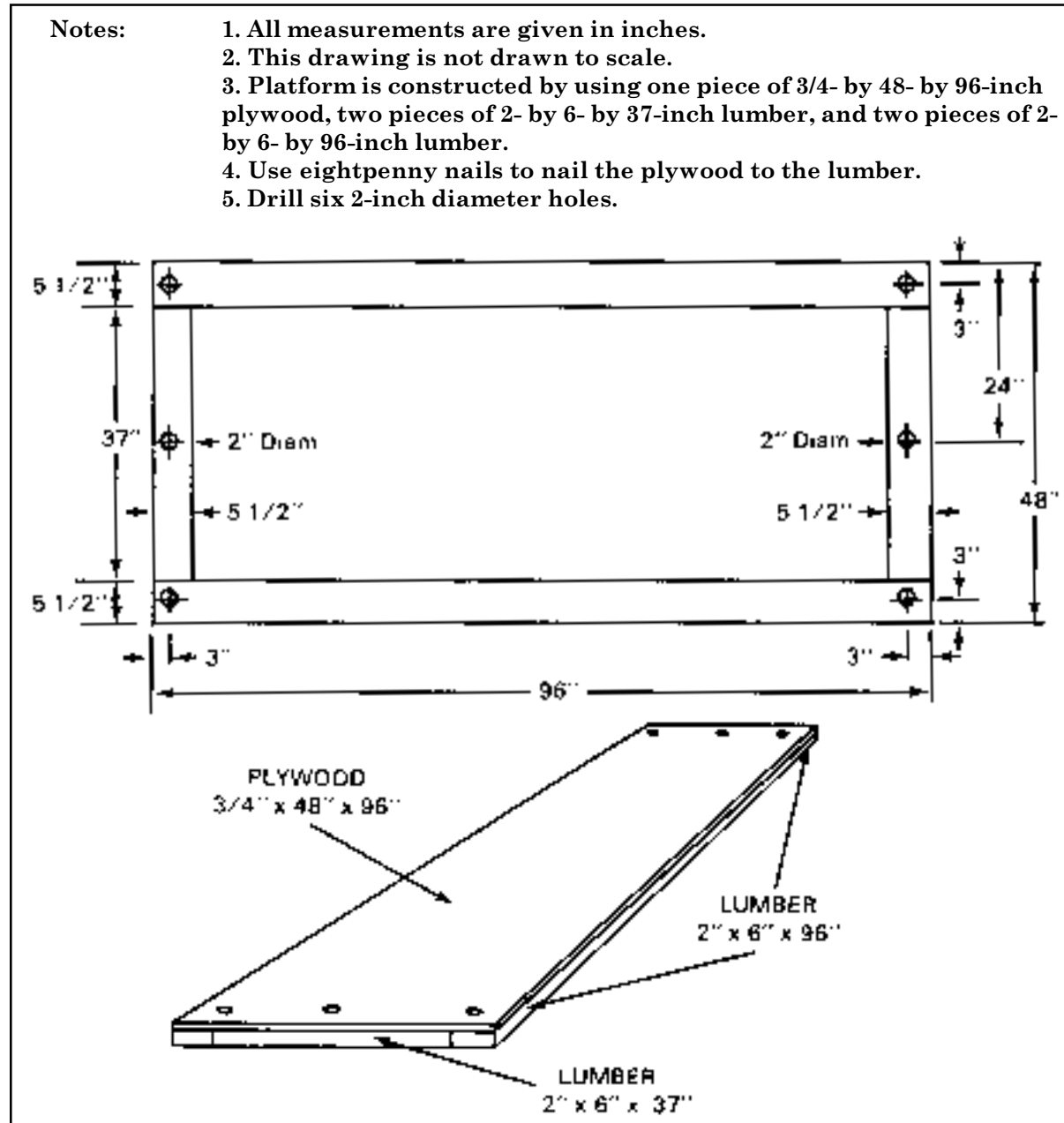

Figure 2-24. Construction Details for Parachute Stowage Platform

b. Securing Stowage Platform. Position and secure the stowage platform as shown in Figure 2-25.

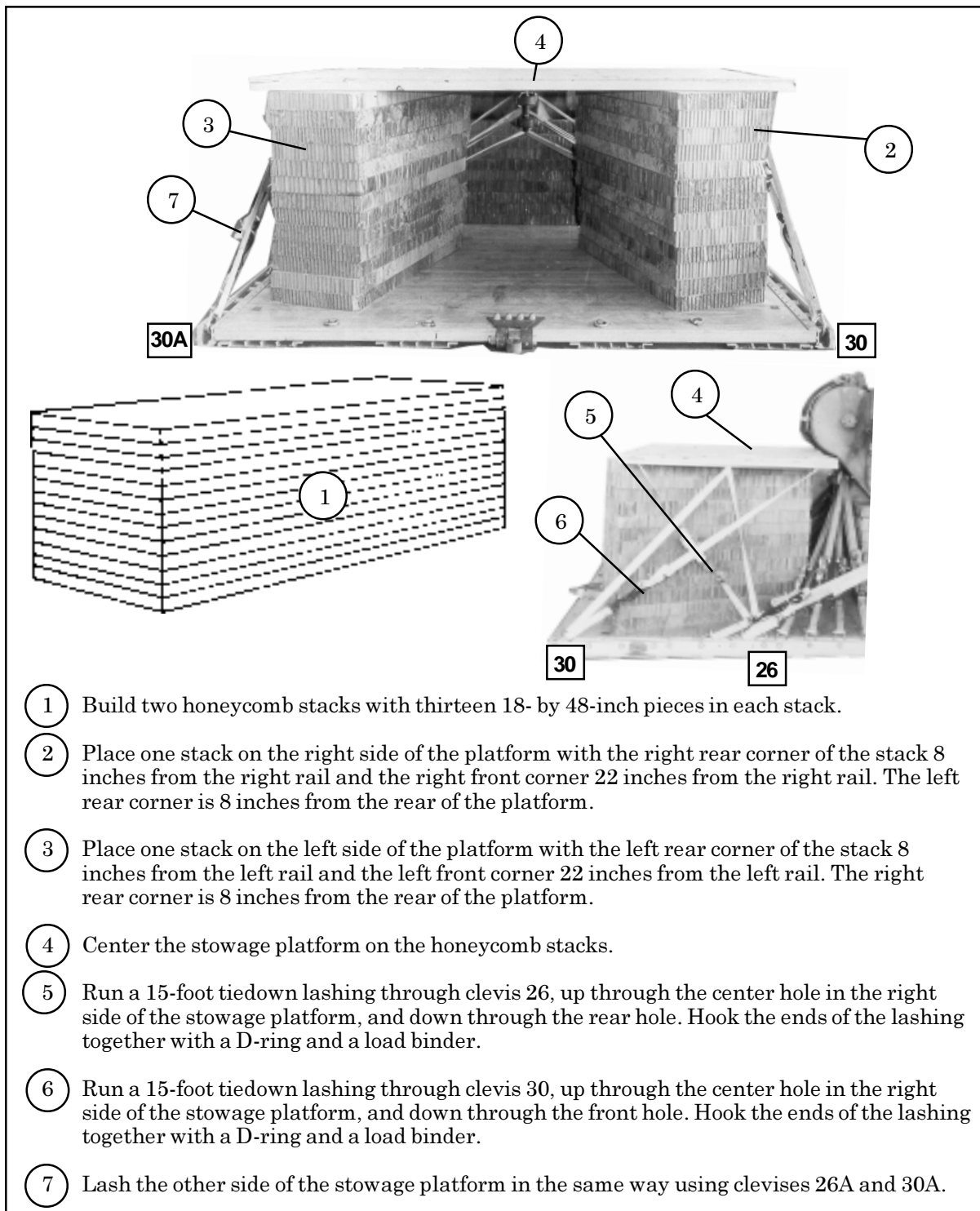

Figure 2-25. Stowage Platform Positioned and Secured

c. **Stowing Parachutes.** Stow the parachutes as shown in Figure 2-26.

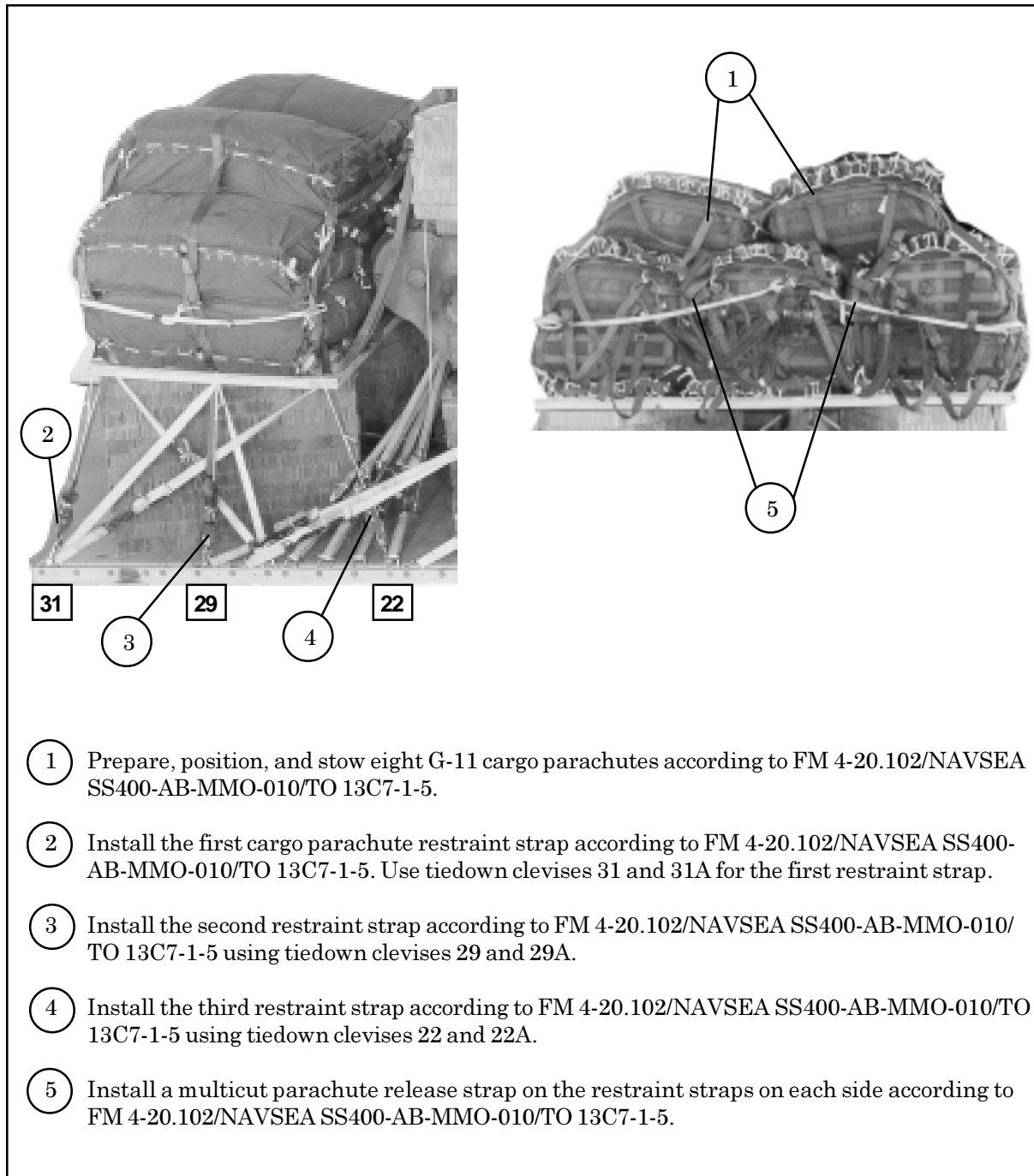

Figure 2-26. Parachute Stowage Platform Positioned, Secured, and Stowed

INSTALLING THE RELEASE SYSTEM

2-14. Prepare the M-2 cargo parachute release assembly according to FM 4-20.102/NAVSEA SS400-AB-MMO-010/TO 13C7-1-5. Install the release assembly as shown in Figure 2-27.

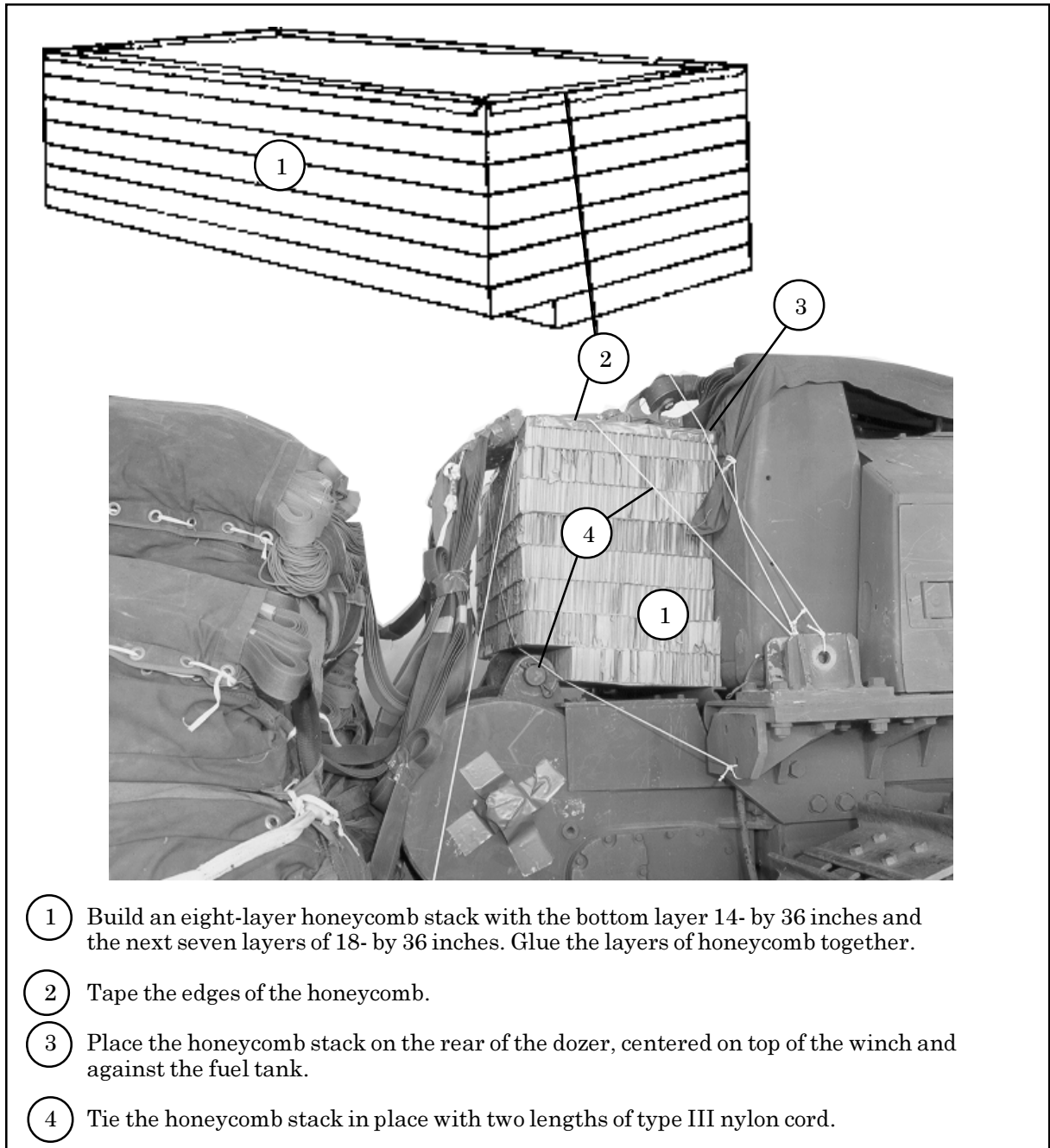
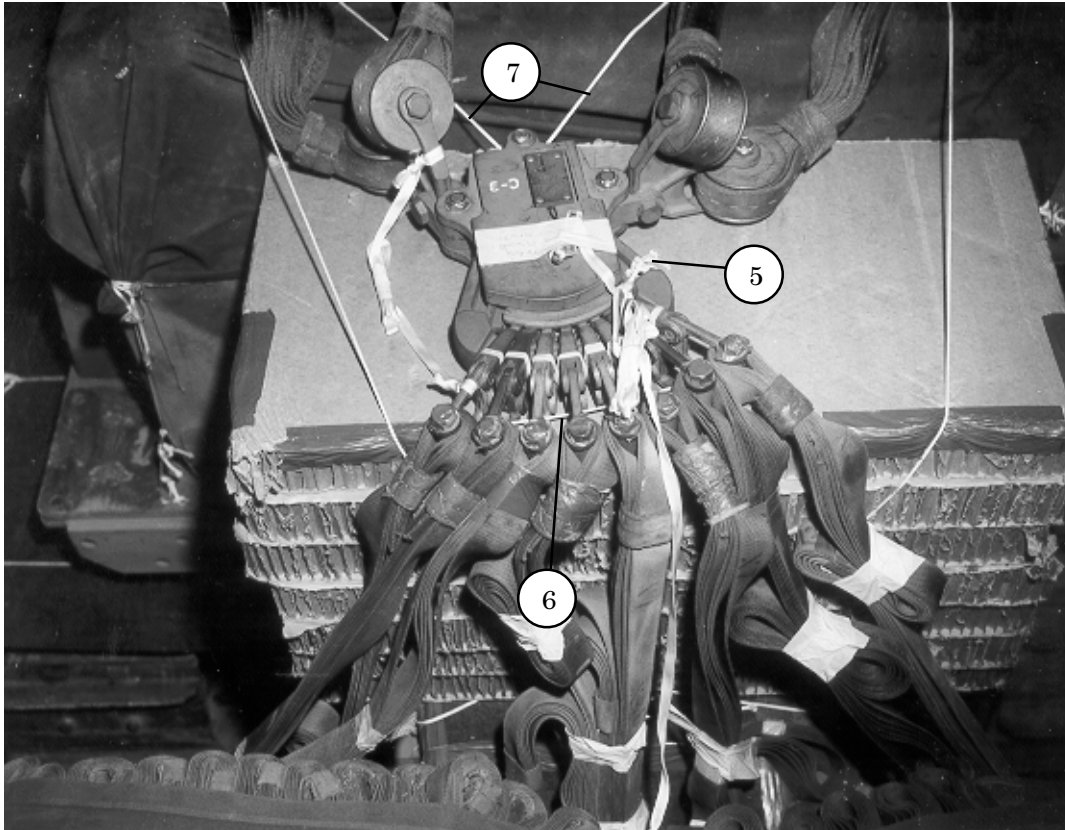

Figure 2-27. M-2 Cargo Parachute Release Assembly Installed



- 5 Place the M-2 cargo parachute release assembly on top of the honeycomb stack and install it according to FM 4-20.102/NAVSEA SS400-AB-MMO-010/TO 13C7-1-5.
- 6 Safety tie the top of the release assembly according to FM 4-20.102/NAVSEA SS400-AB-MMO-010/TO 13C7-1-5.
- 7 Safety tie the bottom of the release assembly according to FM 4-20.102/NAVSEA SS400-AB-MMO-010/TO 13C7-1-5.

Figure 2-27. M-2 Cargo Parachute Release Assembly Installed (Continued)

INSTALLING THE EXTRACTION SYSTEM

2-15. Install the extraction force transfer coupling (EFTC) extraction system according to FM 4-20.102/NAVSEA SS400-AB-MMO-010/TO 13C7-1-5 and as shown in Figure 2-28.

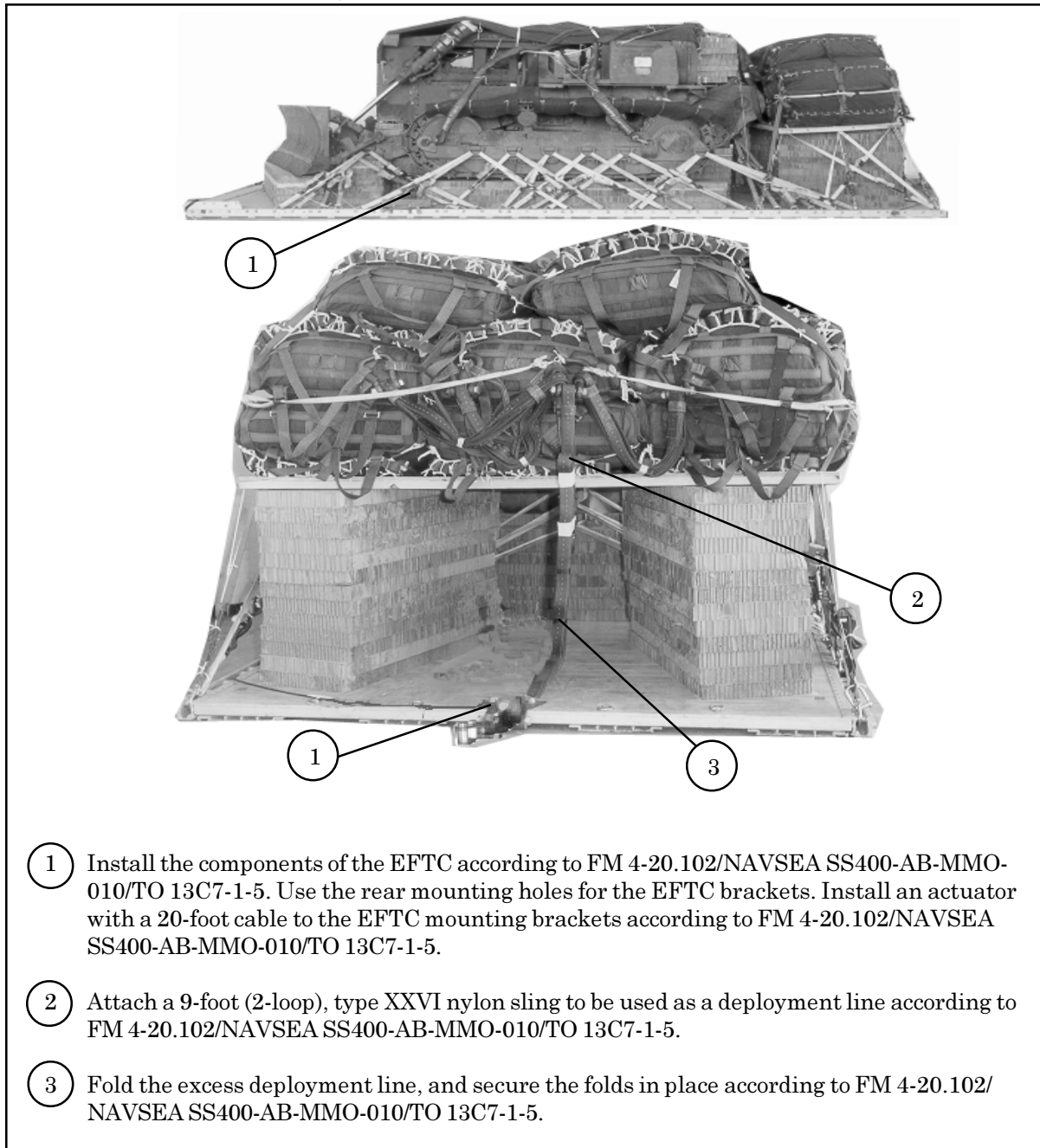

Figure 2-28. Extraction System Installed

INSTALLING PROVISIONS FOR EMERGENCY RESTRAINTS

2-16. Install the provisions for emergency restraints on the load according to FM 4-20.102/NAVSEA SS400-AB-MMO-010/TO 13C7-1-5.

PLACING EXTRACTION PARACHUTE

2-17. Select the extraction parachute and extraction line needed using the extraction line requirements table in FM 4-20.102/NAVSEA SS400-AB-MMO-010/TO 13C7-1-5. Rig the extraction line in an extraction line bag according to TM 10-1670-286-20/TO 13C5-2-41. Place the extraction parachute and extraction line on the load for installation in the aircraft.

MARKING RIGGED LOAD

2-18. Mark the rigged load according to FM 4-20.102/NAVSEA SS400-AB-MMO-010/TO 13C7-1-5, and as shown in Figure 2-29. Complete Shipper's Declaration for Dangerous Goods. If the load varies from the one shown, the weight, height, CB, and parachute requirements must be recomputed.

EQUIPMENT REQUIRED

2-19. Use the equipment listed in Table 2-1 to rig this load.

CAUTION
**Make the final rigger inspection required by FM 4-20.102/NAVSEA SS 400-AB-
 MMO-010/TO 13C7-1-5 before the load leaves the rigging site.**

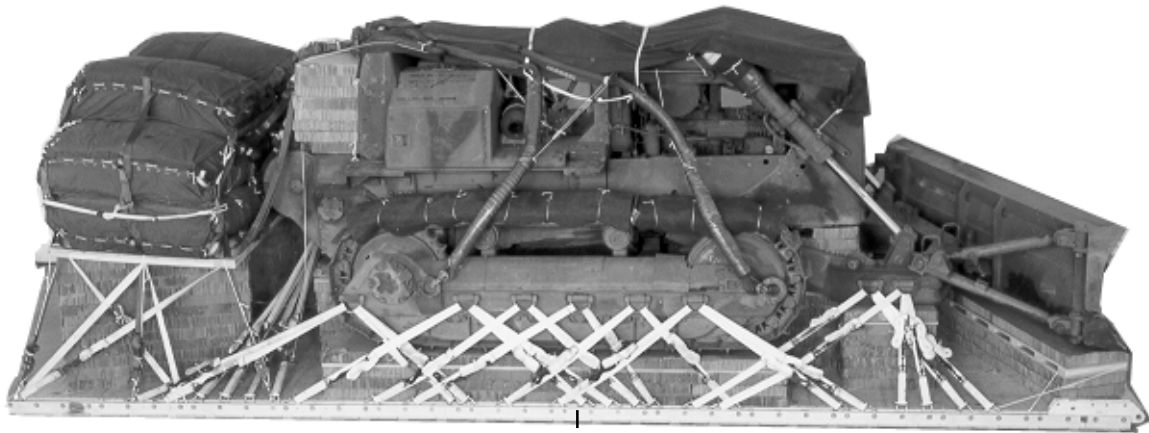

C/B

RIGGED LOAD DATA

Weight Load Shown.....	36,140 pounds
Maximum Allowed.....	37,100 pounds
Height.....	98 inches
Width.....	108 inches
Length	306 inches
Overhang: Front.....	5 inches
Rear.....	18 inches
Center of Balance (CB) (from front edge of the platform)	152 inches
Extraction System	EFTC

Figure 2-29. Tractor-Dozer Rigged for Low-Velocity Airdrop

Table 2-1. Equipment Required for Rigging the Type I, D-5B Tractor-Dozer for Low-Velocity Airdrop

National Stock Number	Item	Quantity
8040-00-273-8713	Adhesive paste, 1-gal.	As required
4030-00-432-2516	Clevis, screw-pin, large	4
4030-00-090-5354	Clevis, suspension, 1-inch (large)	15
8305-00-880-8155	Cloth, coated (nyl, type II, 17.0 oz, green, 60-in)	As required
4020-00-240-2146	Cord, nylon, type III, 550-lb.	As required
1670-00-434-5787	Coupling, airdrop extraction force transfer, w/20-ft. cable	1
1670-00-360-0328	Cover, clevis	6
8135-00-664-6958	Cushioning material (Cellulose wadding)	As required
8305-00-958-3685	Felt, 1/2-inch thick	As required
1670-01-183-2678	Leaf, extraction line (line bag) (add 2 for C-17)	2
	Line extraction:	
1670-01-064-4454	60-foot (6-loop), type XXVI (for C-130)	1
1670-01-062-6312	120-foot (6-loop), type XXVI (for C-141)	1
1670-01-468-9178	140-foot (6-loop), type XXVI (for C-17)	1
1670-01-064-4452	60-foot (1-loop), type XXVI (for C-17), (drogue line)	1
1670-00-783-5988	Link assembly, type IV (C-17 only)	1
	Link assembly, two-point:	
5306-00-435-8994	Bolt, 1-inch diameter, 4-inches long (add 4 for C-5)	4
5310-00-232-5165	Nut, 1-inch (add 4 for C-5)	4
1670-00-003-1954	Plate, side, 5 1/2-inch	4
5365-00-007-3414	Spacer, large (add 4 for C-5)	4
1670-00-006-2752	Link, four-point	1
	Lumber:	
5510-00-220-6146	2- by 4- by 18-inch	9
	2- by 6- by 37-inch	2
	2- by 6- by 96-inch	2
5315-00-753-3885	Nail, steel, common, 16D	As required
1670-00-753-3928	Pad, energy-dissipating (honeycomb) 3- by 36- by 96-inches	28 sheets

Table 2-1. Equipment Required for Rigging the Type I, D-5B Tractor-Dozer for Low-Velocity Airdrop (Continued)

National Stock Number	Item	Quantity
1670-01-016-7841	Parachute, cargo, G-11C	8
1670-00-040-8135	Parachute, cargo, extraction: 28-ft.	2
1670-01-063-3715	15-ft. (C-17 only)	1
1670-01-162-2372	Platform, airdrop, type V, 24-ft: Clevis assembly (type V)	(68)
1670-01-162-2376	Extraction bracket assembly	(1)
1670-01-162-2381	Tandem link assembly (Multipurpose link)	(2)
5530-00-128-4981	Plywood, 3/4-inch:	5 sheets
1670-01-097-8817	Release, cargo parachute, M-2	1
1670-01-062-6306	Sling, cargo, airdrop: 3-ft. (4-loop), type XXVI	5
1670-01-062-6304	9-ft. (2-loop), type XXVI	1
1670-01-062-6307	12-ft. (4-loop), type XXVI	4
5340-00-040-8219	Strap, parachute, release, multi-knife	2
7501-00-266-5016	Tape, adhesive, 2-inch	As required
1670-00-937-0271	Tiedown assembly, 15-ft.	57
1670-01-483-8259	Towplate release mechanism (H-block) (C-17 only)	1
8305-00-268-2411	Webbing: Cotton, 1/4-inch, type I	As required
8305-00-082-5752	Nylon, tubular, 1/2-inch	As required
8305-00-260-6890	Nylon, type X	As required
8305-00-268-2455	Nylon, tubular, 1-inch, OD 7	As required

Chapter 3

RIGGING THE JOHN DEERE 450G LT TRACKED COMMERCIAL BULLDOZER ON A 16-FOOT, TYPE V PLATFORM FOR LOW-VELOCITY AIRDROP

DESCRIPTION OF LOAD

3-1. The John Deere 450G Lt Full Tracked Commercial Bulldozer is rigged on a 16-foot, type V airdrop platform with four G-11 cargo parachutes. The unrigged dozer weighs 18,080 pounds reduced to 17,440 pounds with the roll-over protection structure (ROPS) removed. It is 180 1/3 inches long. It is 97 inches wide and 108 inches high reducible to 77 inches with the ROPS removed and the back seat back lowered.

PREPARING PLATFORM

3-2. Prepare a 16-foot, type V airdrop as shown in Figure 3-1.

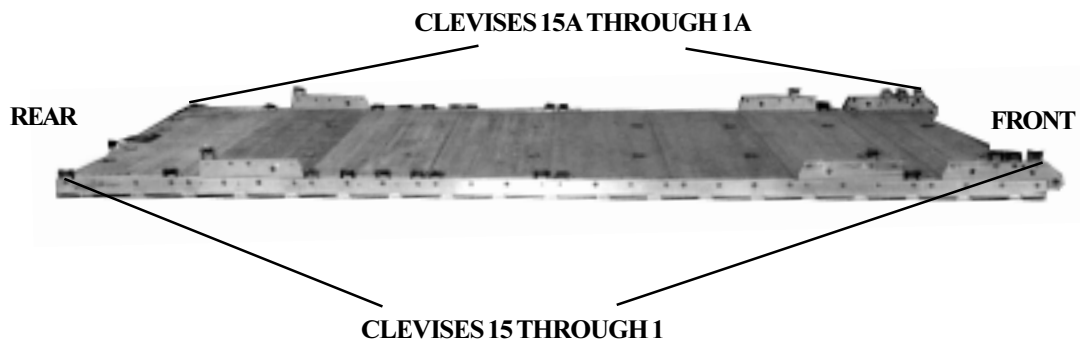

Step:

1. Inspect, or assemble and inspect, a 16-foot, type V airdrop platform as outlined in TM 10-1670-268-20&P/TO 13C7-52-22.
2. Install a tandem link to the front of each platform side rail using holes 1, 2, and 3.
3. Install a suspension link on bushings 6, 7, 8 for forward and 25, 26, and 27 for aft on each platform side rail.
4. Install a clevis on bushings 1, 2, and 3 on the tandem links.
5. Install a clevis on bushing 2 on the forward suspension links.
6. Install a clevis on bushing 3 on the aft suspension links.
7. Starting at the front of each platform side rail, install clevises on the bushings bolted on holes 5, 16, 17, 20, 21, 22, 23, 24, 29, and 32.
8. Starting at the front of the platform, number the clevises 1 through 15 on the right side and 1A through 15A on the left side.
9. Label the tiedown rings according to FM 4-20.102/NAVSEA SS400-AB-MMO-010/TO 13C7-1-5.

Figure 3-1. Platform prepared

BUILDING AND POSITIONING HONEYCOMB STACKS

3-3. Build the honeycomb stacks as shown in Figures 3-2 through 3-6. Position the stacks as shown in Figure 3-7.

**Notes: 1. All measurements are given in inches.
2. This drawing is not drawn to scale.**



Stack Number	Pieces	Width (Inches)	Length (Inches)	Material	Instructions
1	9	21	21	Honeycomb	Glue pieces together.

Figure 3-2. Honeycomb Stack 1 Prepared

Notes: 1. All measurements are given in inches.
 2. This drawing is not drawn to scale.

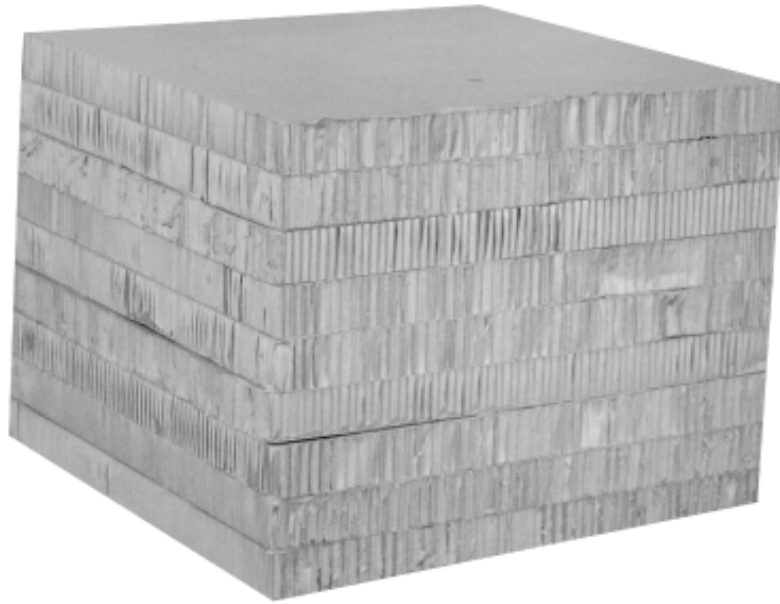

Stack Number	Pieces	Width (Inches)	Length (Inches)	Material	Instructions
2	9	36	36	Honeycomb	Glue pieces together.

Figure 3-3. Honeycomb Stack 2 Prepared

**Notes: 1. All measurements are given in inches.
2. This drawing is not drawn to scale.**

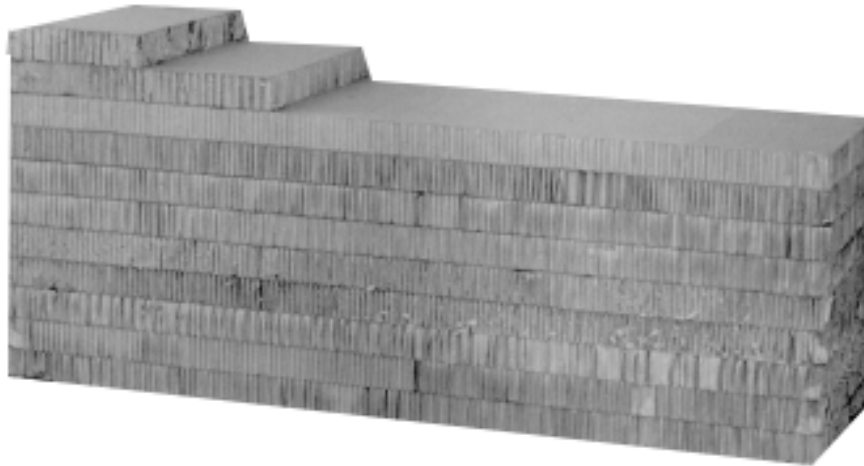

Stack Number	Pieces	Width (Inches)	Length (Inches)	Material	Instructions
3	9	28	76	Honeycomb	Glue to form the base.
	1	28	26	Honeycomb	Glue to base flush with rear edge.
	1	28	13	Honeycomb	Glue the 28-inch by 13-inch piece flush with rear edge.

Figure 3-4. Honeycomb Stack 3 Prepared

- Notes: 1. All measurements are given in inches.
2. This drawing is not drawn to scale.**

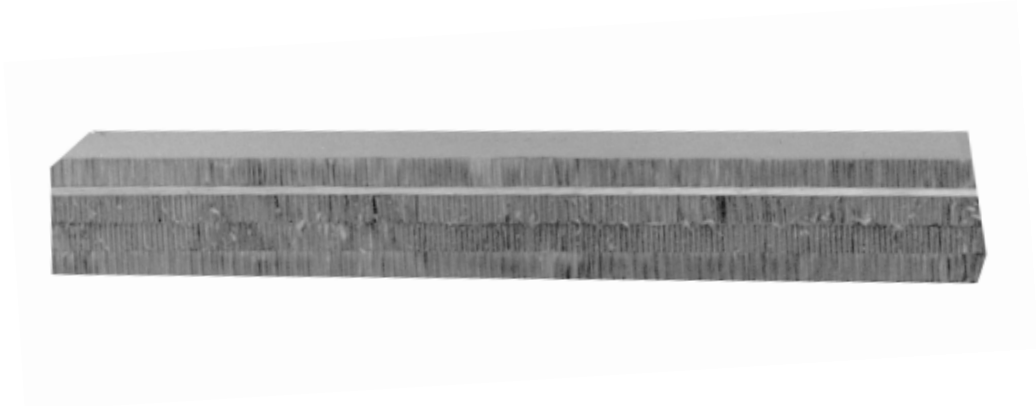

Stack Number	Pieces	Width (Inches)	Length (Inches)	Material	Instructions
4 and 5	3	18	96	Honeycomb	Glue to form the base.
	1	18	96	3/4-inch plywood	Glue to base.
	1	18	96	Honeycomb	Glue to plywood.

Figure 3-5. Honeycomb Stacks 4 and 5 Prepared

Notes: 1. All measurements are given in inches.
 2. This drawing is not drawn to scale.

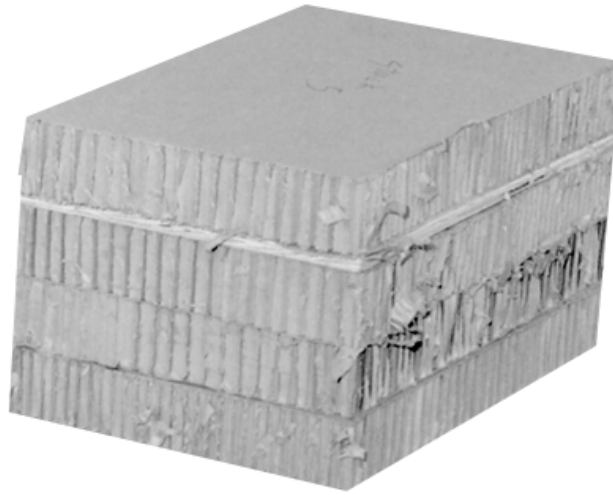

Stack Number	Pieces	Width (Inches)	Length (Inches)	Material	Instructions
6 and 7	3	24	15	Honeycomb	Glue to form the base.
	1	24	15	3/4-inch plywood	Glue to base.
	1	24	15	Honeycomb	Glue to plywood.

Figure 3-6. Honeycomb Stacks 6 and 7 Prepared

- Notes: 1. All measurements are given in inches.
 2. This drawing is not drawn to scale.

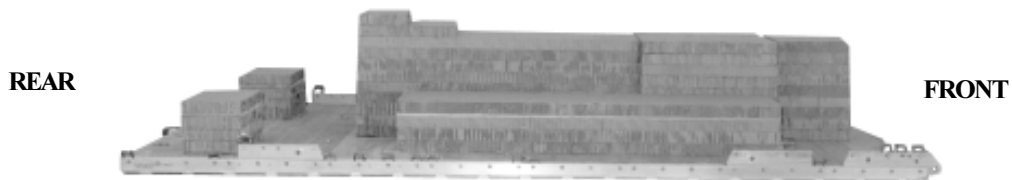
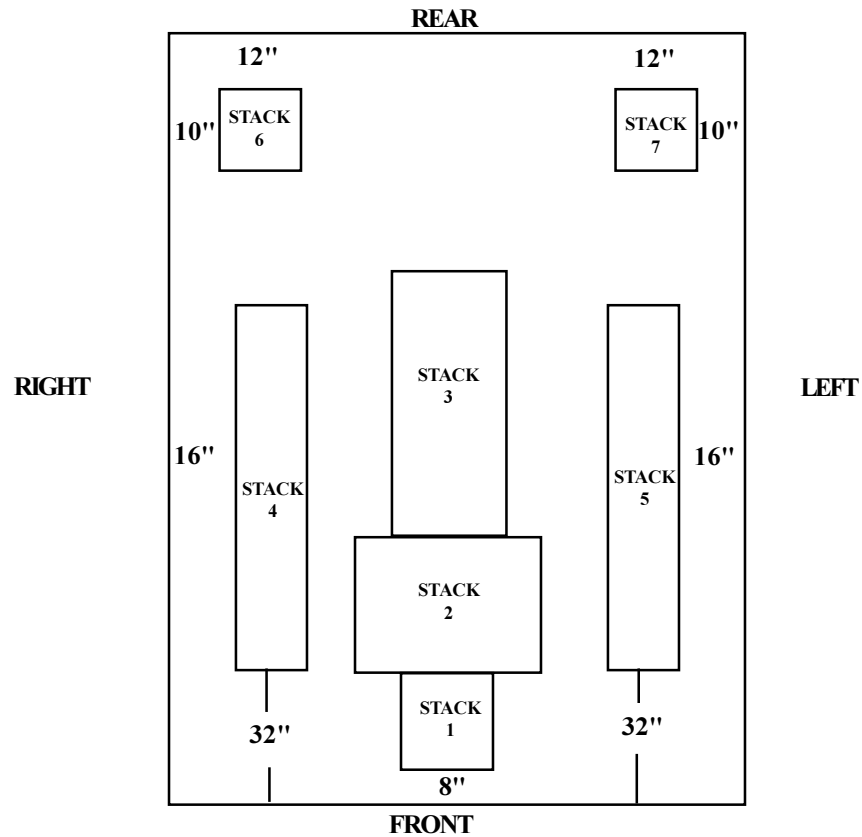

Step:

1. Position stack 1 centered and 8 inches from the front edge of the platform.
2. Position stack 2 centered and flush with the rear of stack 1.
3. Position stack 3 centered and flush with the rear of stack 2.
4. Position stacks 4 and 5 on each side of the platform 32 inches from the front edge of the platform and 16 inches from the sides of the platform.
5. Position stacks 6 and 7 on each side of the platform 12 inches from the rear edge of the platform and 10 inches from the sides of the platform.

Figure 3-7. Honeycomb Stacks Positioned on Platform

PREPARING DOZER

3-4. Prepare the dozer as shown in Figure 3-8.

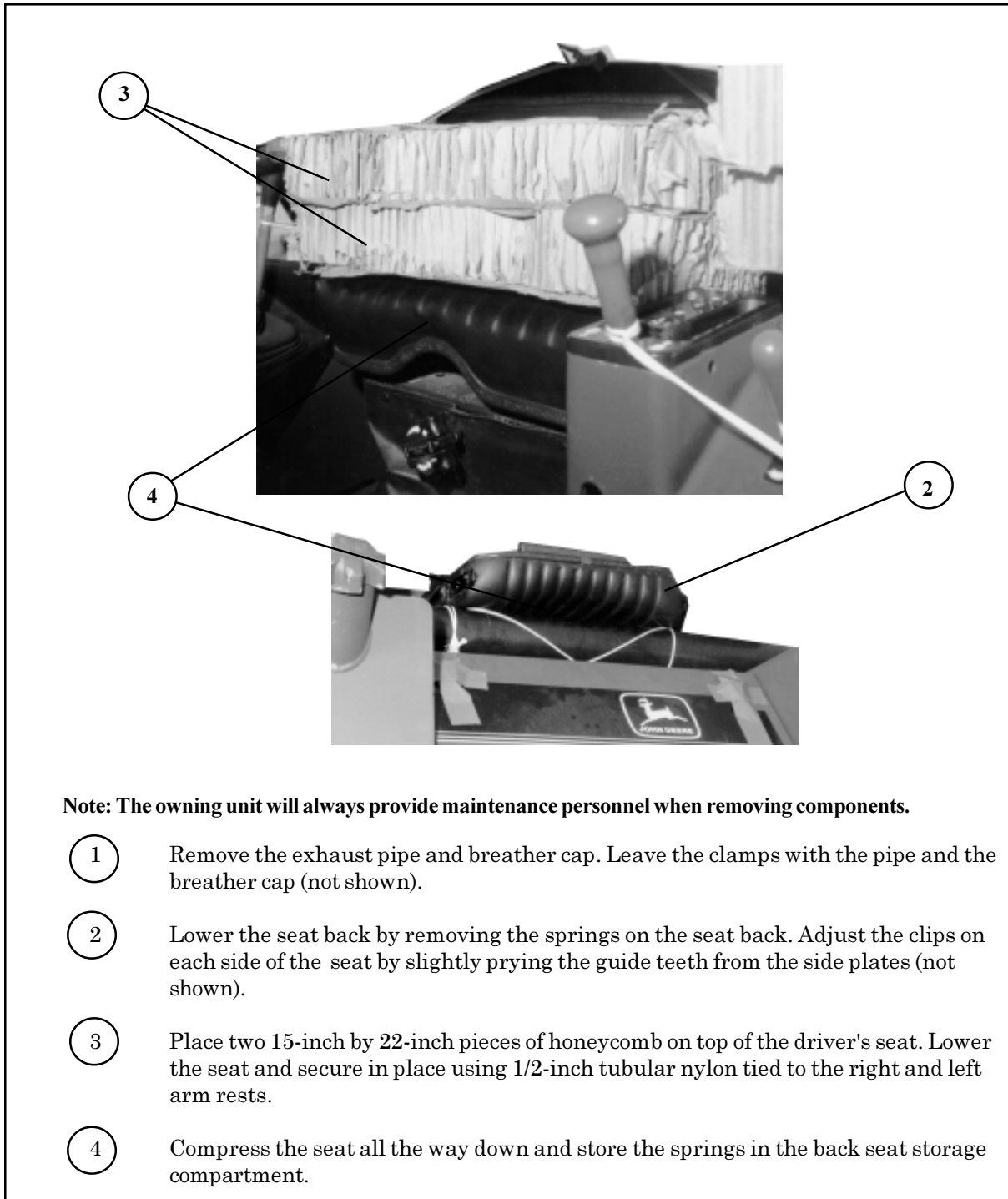

Note: The owning unit will always provide maintenance personnel when removing components.

- ① Remove the exhaust pipe and breather cap. Leave the clamps with the pipe and the breather cap (not shown).
- ② Lower the seat back by removing the springs on the seat back. Adjust the clips on each side of the seat by slightly prying the guide teeth from the side plates (not shown).
- ③ Place two 15-inch by 22-inch pieces of honeycomb on top of the driver's seat. Lower the seat and secure in place using 1/2-inch tubular nylon tied to the right and left arm rests.
- ④ Compress the seat all the way down and store the springs in the back seat storage compartment.

Figure 3-8. Dozer Prepared

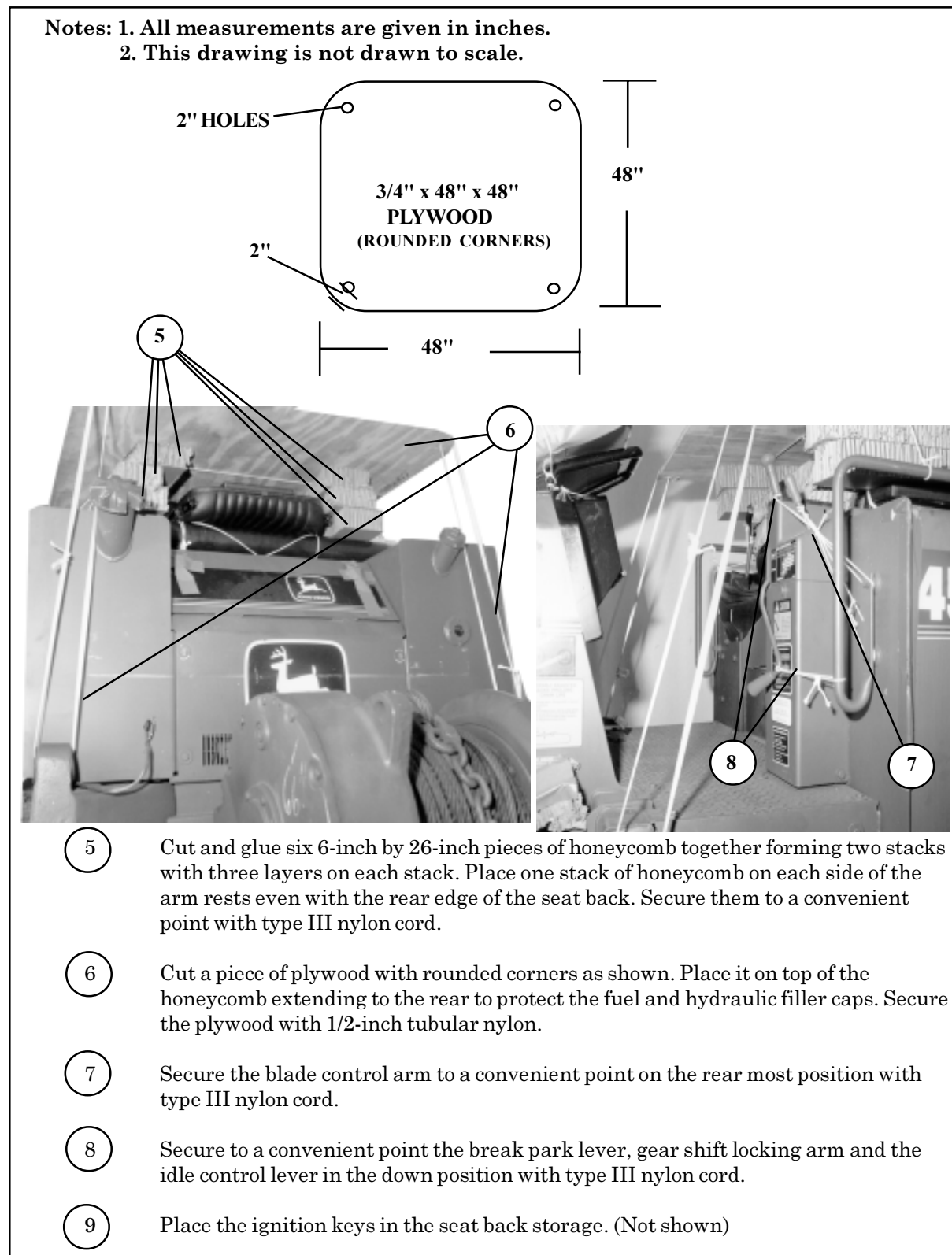

Figure 3-8. Dozer Prepared (Continued)

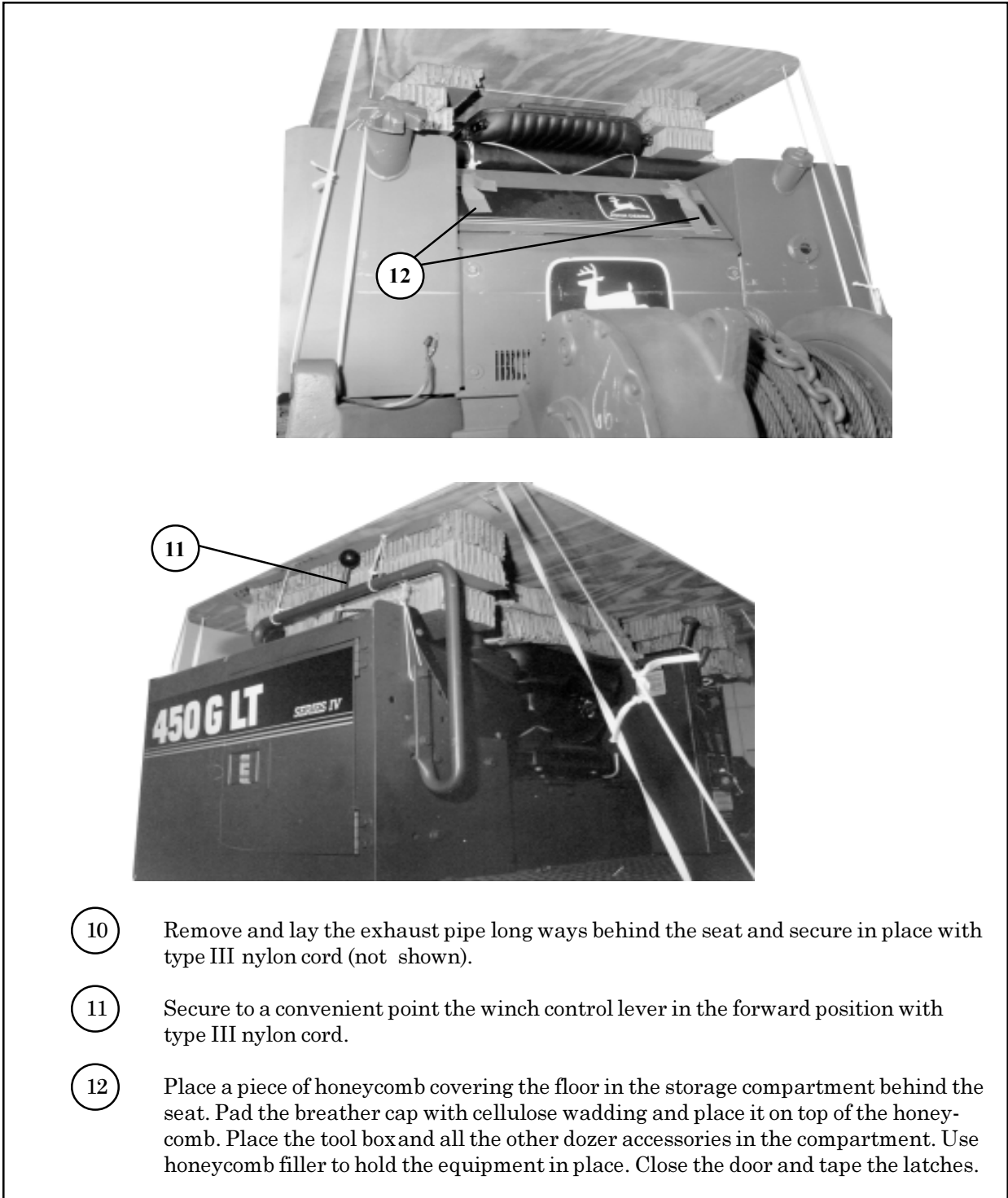

Figure 3-8. Dozer Prepared (Continued)

LIFTING AND POSITIONING DOZER

3-5. Lift and position the dozer as shown in Figure 3-9.

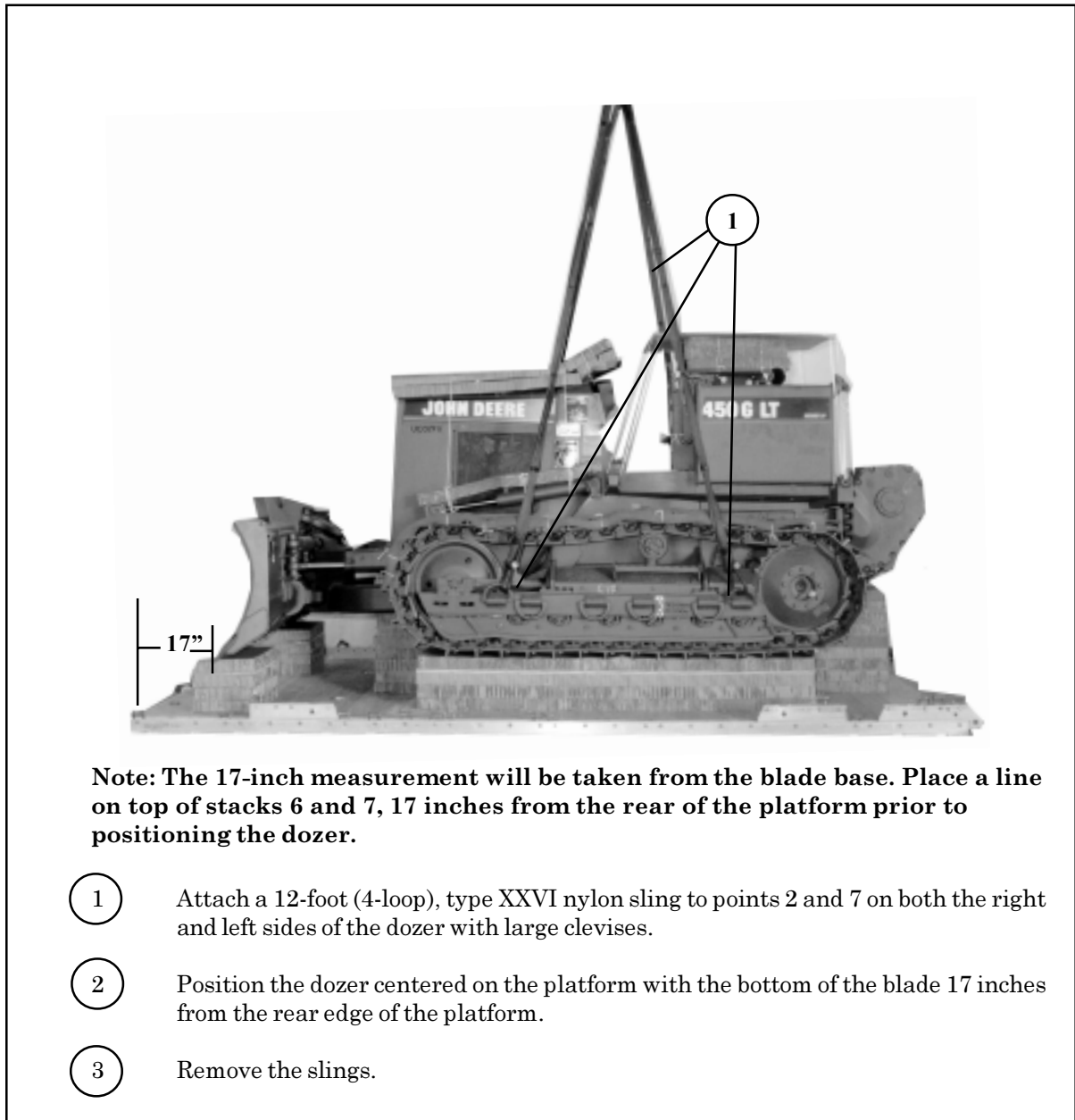
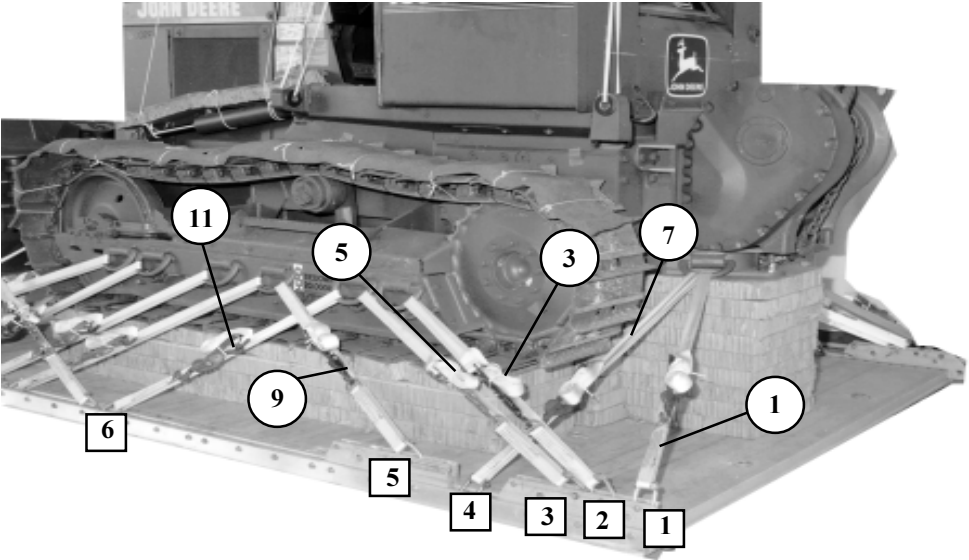

Figure 3-9. Dozer Lifted and Positioned on Platform

LASHING DOZER TO PLATFORM

3-6. Lash the dozer to the platform as shown in Figure 3-10.



Lashing Number	Tiedown Clevis Number	Instructions
1	1	Pass lashing through: Tiedown point 8, left side.
2	1A	Tiedown point 8, right side.
3	2	Tiedown point 7, left side.
4	2A	Tiedown point 7, right side.
5	3	Tiedown point 6, left side.
6	3A	Tiedown point 6, right side.
7	4	Tiedown point 8, left side.
8	4A	Tiedown point 8, right side.
9	5	Tiedown point 5, left side.
10	5A	Tiedown point 5, right side.
11	6	Tiedown point 6, left side.
12	6A	Tiedown point 6, right side.

Figure 3-10. Dozer Lashed to Platform

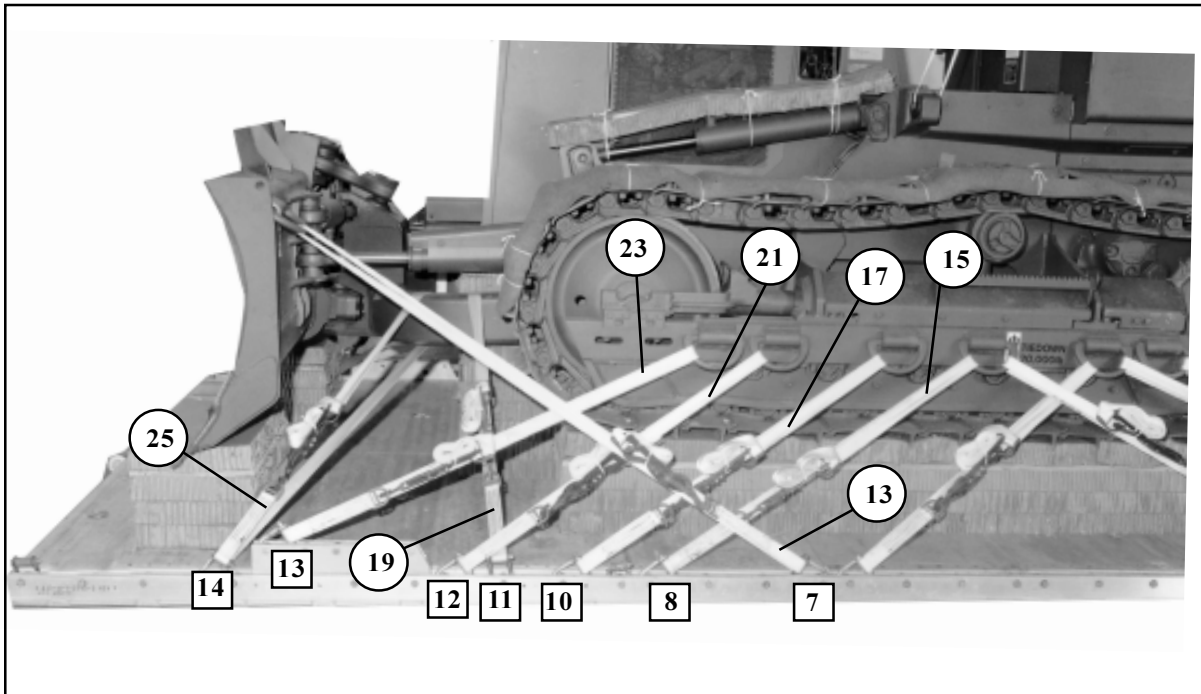

Lashing Number	Tiedown Clevis Number	Instructions
		Pass lashing:
13	7	Through tiedown point 1, left side.
14	7A	Through tiedown point 1, right side.
15	8	Through tiedown point 5, left side.
16	8A	Through tiedown point 5, right side.
17	10	Through tiedown point 4, left side.
18	10A	Through tiedown point 4, right side.
19	11	Around yoke of blade support, left side.
20	11A	Around yoke of blade support, right side.
21	12	Through tiedown point 3, left side.
22	12A	Through tiedown point 3, right side.
23	13	Through tiedown point 2, left side.
24	13A	Through tiedown point 2, right side.
25	14	Around yoke of blade support, left side.
26	14A	Around yoke of blade support, right side.

Figure 3-10. Dozer Lashed to Platform (Continued)

INSTALLING SUSPENSION SLINGS, DEADMAN'S TIE AND LOAD COVER

3-7. Install the suspension slings, deadman's tie and the load cover as shown in Figure 3-11.

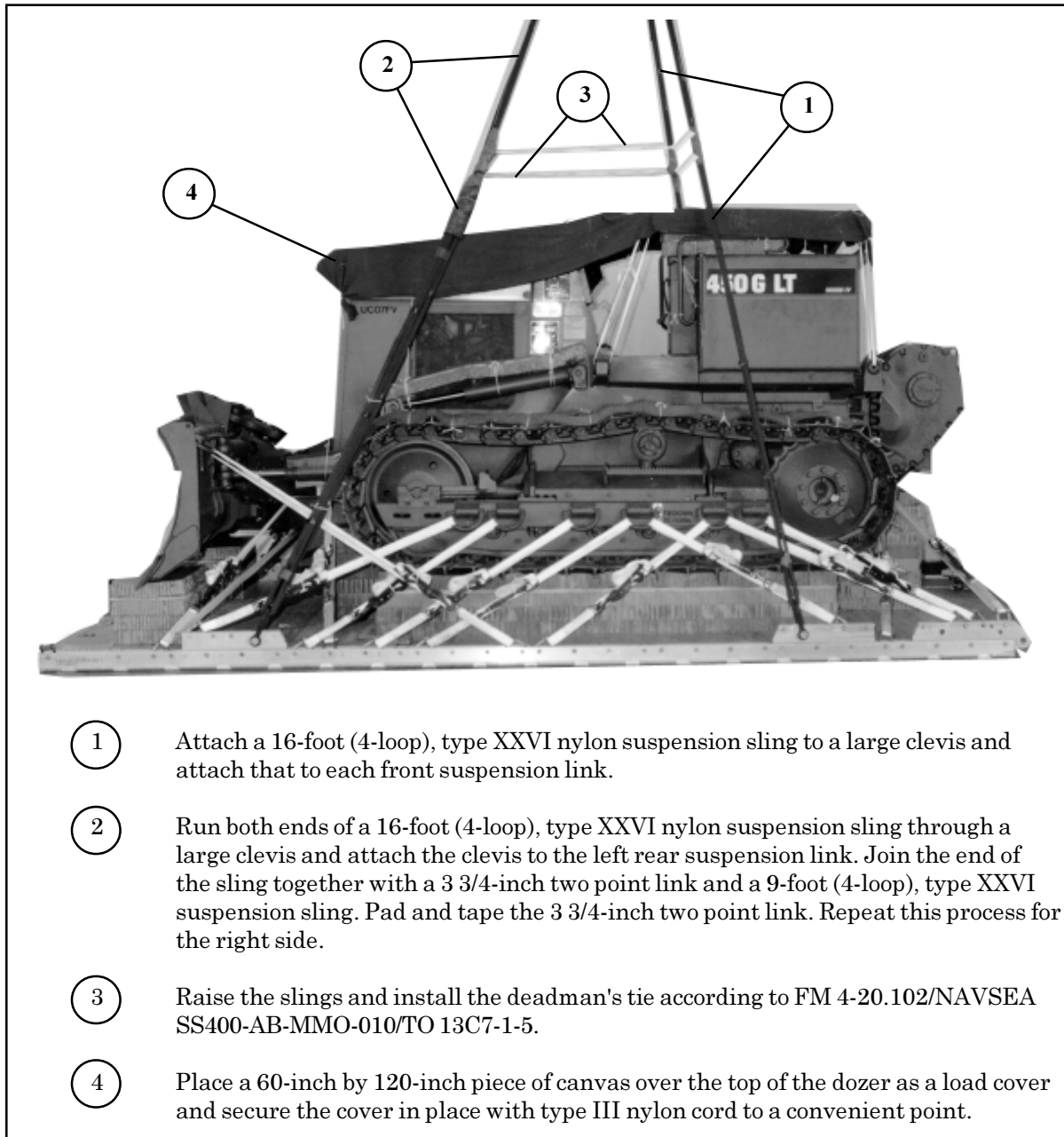

Figure 3-11. Suspension Slings, Deadman's Tie and Cover Installed

BUILDING AND POSITIONING PARACHUTE STOWAGE PLATFORM SUPPORT STACKS

3-8. Build and position two parachute stowage platform support stacks as shown in Figure 3-12.

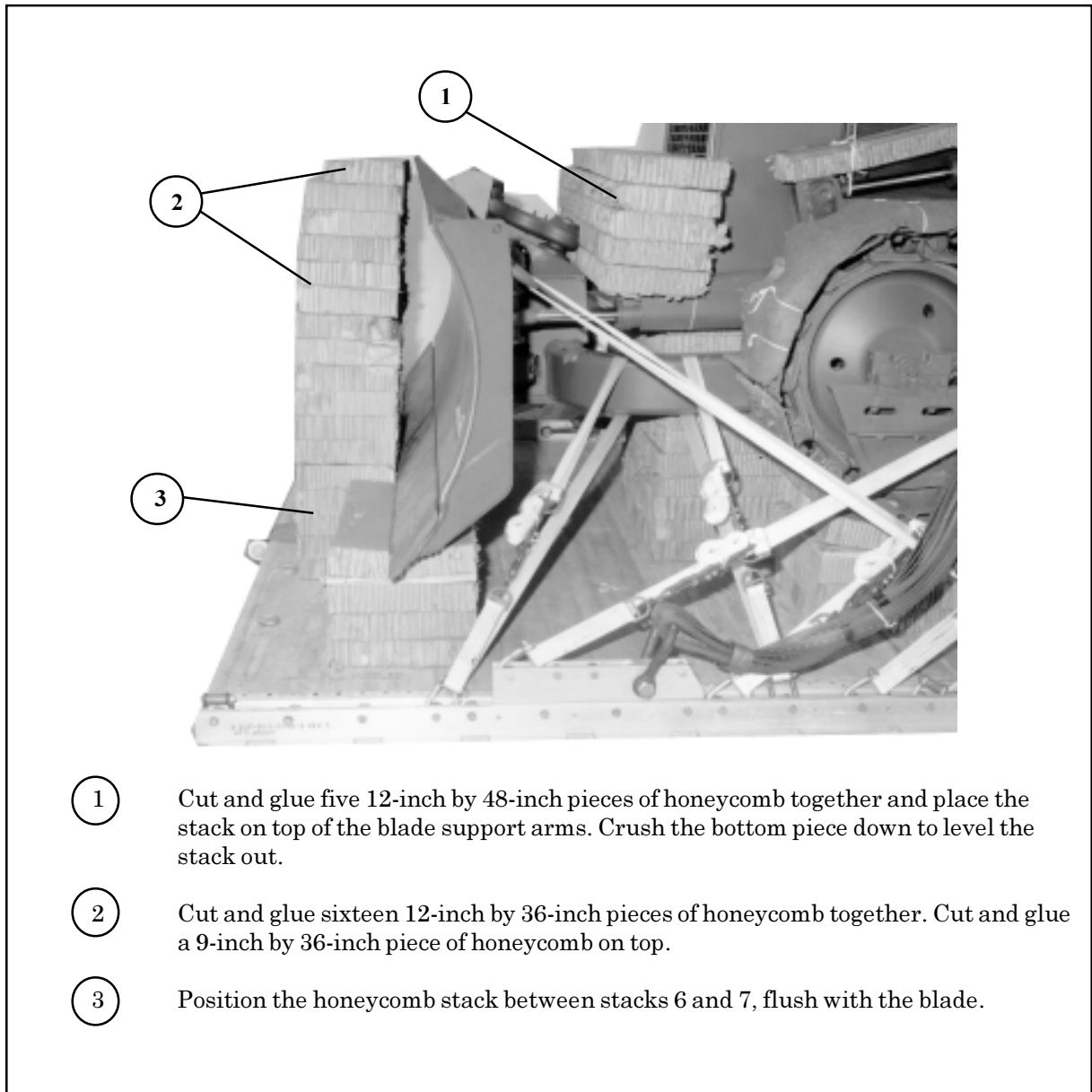

Figure 3-12. Parachute Stowage Platform Support Stacks Built and Positioned

BUILDING PARACHUTE STOWAGE PLATFORM

3-9. Build a parachute stowage platform as shown in Figure 3-13.

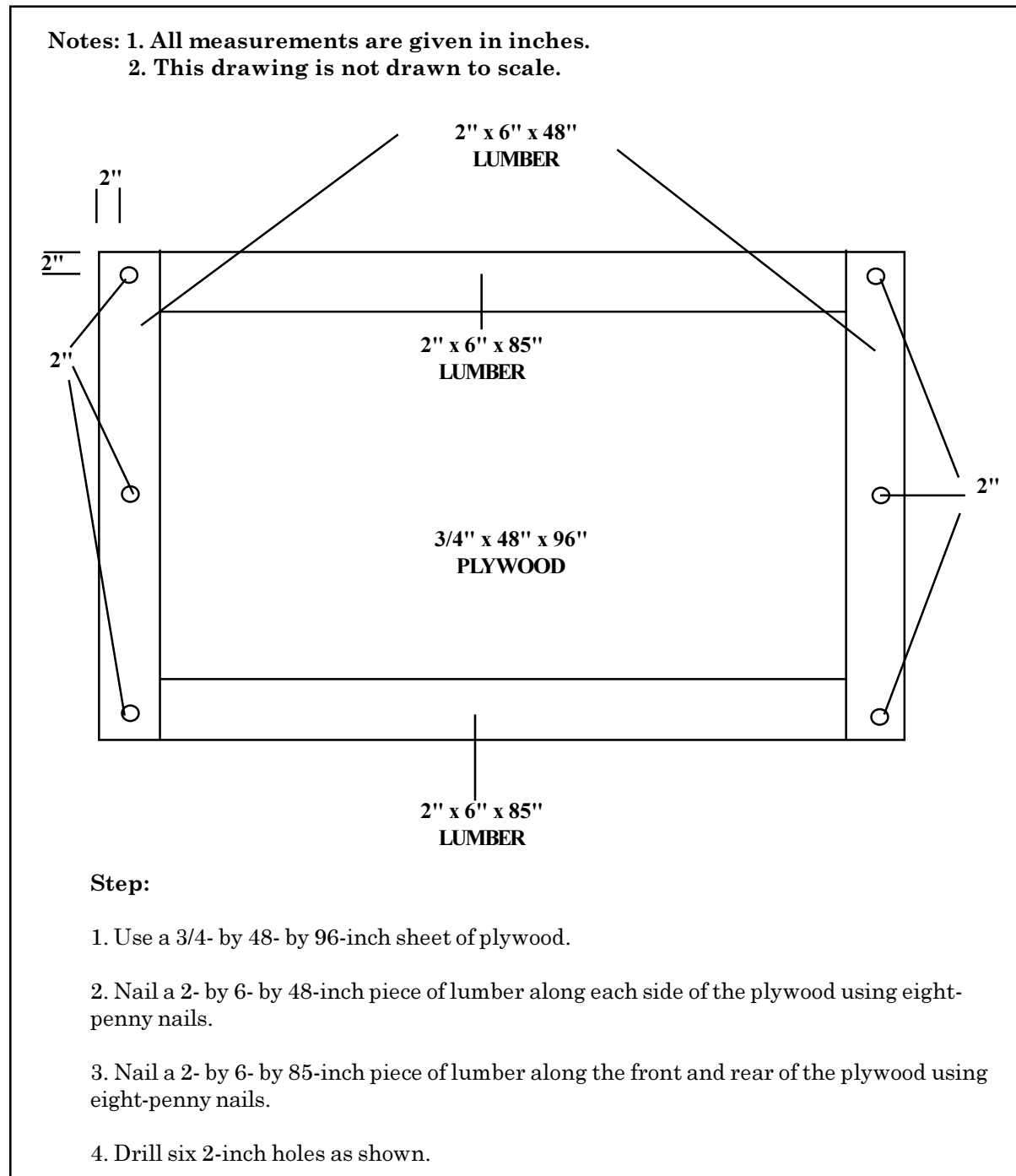

Figure 3-13. Parachute Stowage Platform Built

INSTALLING PARACHUTE STOWAGE PLATFORM AND STOWING CARGO PARACHUTES

3-10. Install the parachute stowage platform on top of the support stacks. Prepare and stow the cargo parachutes as shown in Figure 3-14.

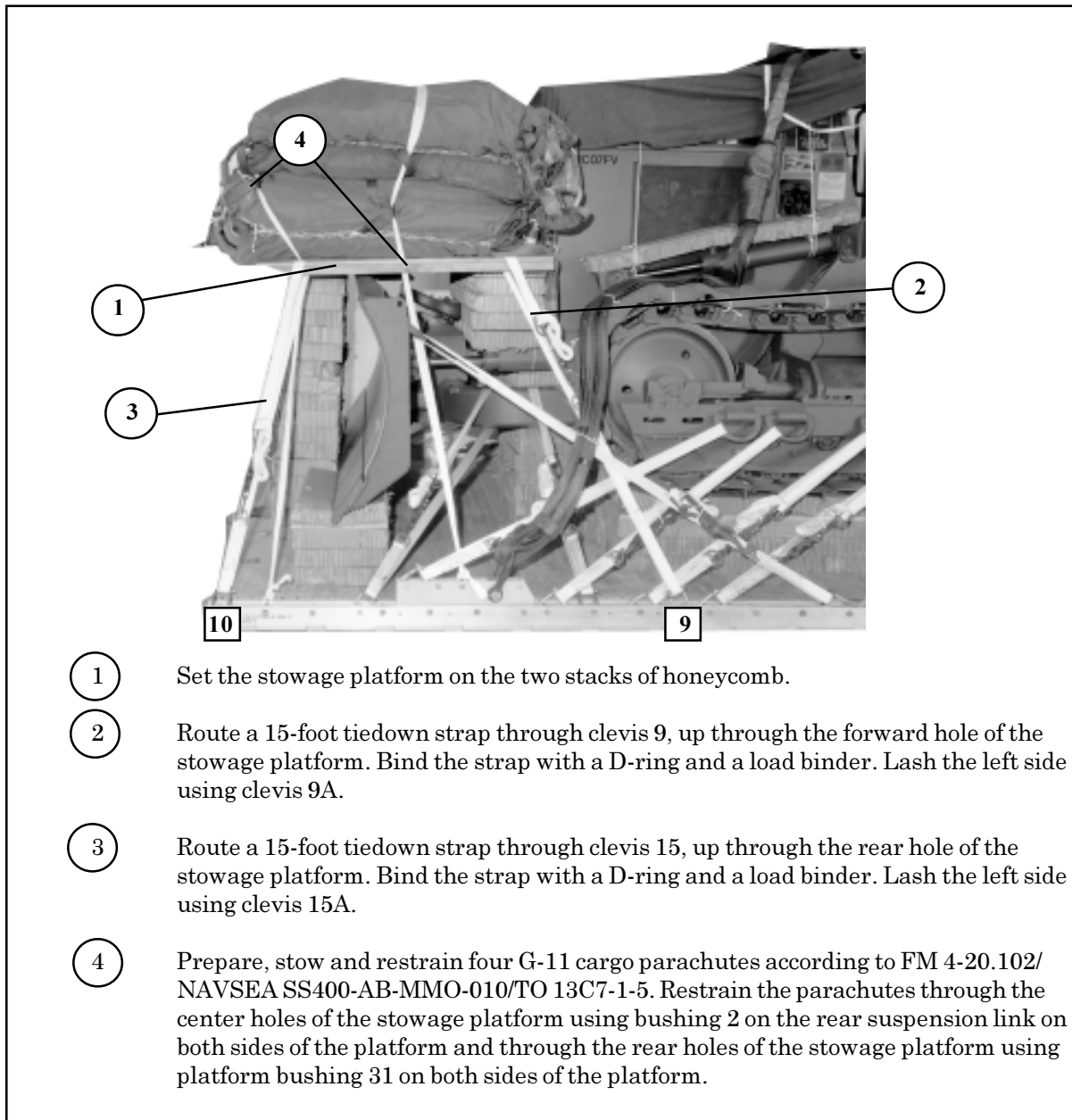

Figure 3-14. Parachute Stowage Platform Installed and Parachutes Prepared and Stowed

INSTALLING EXTRACTION SYSTEM

3-11. Install the extraction force transfer coupling (EFTC) as shown in Figure 3-15.

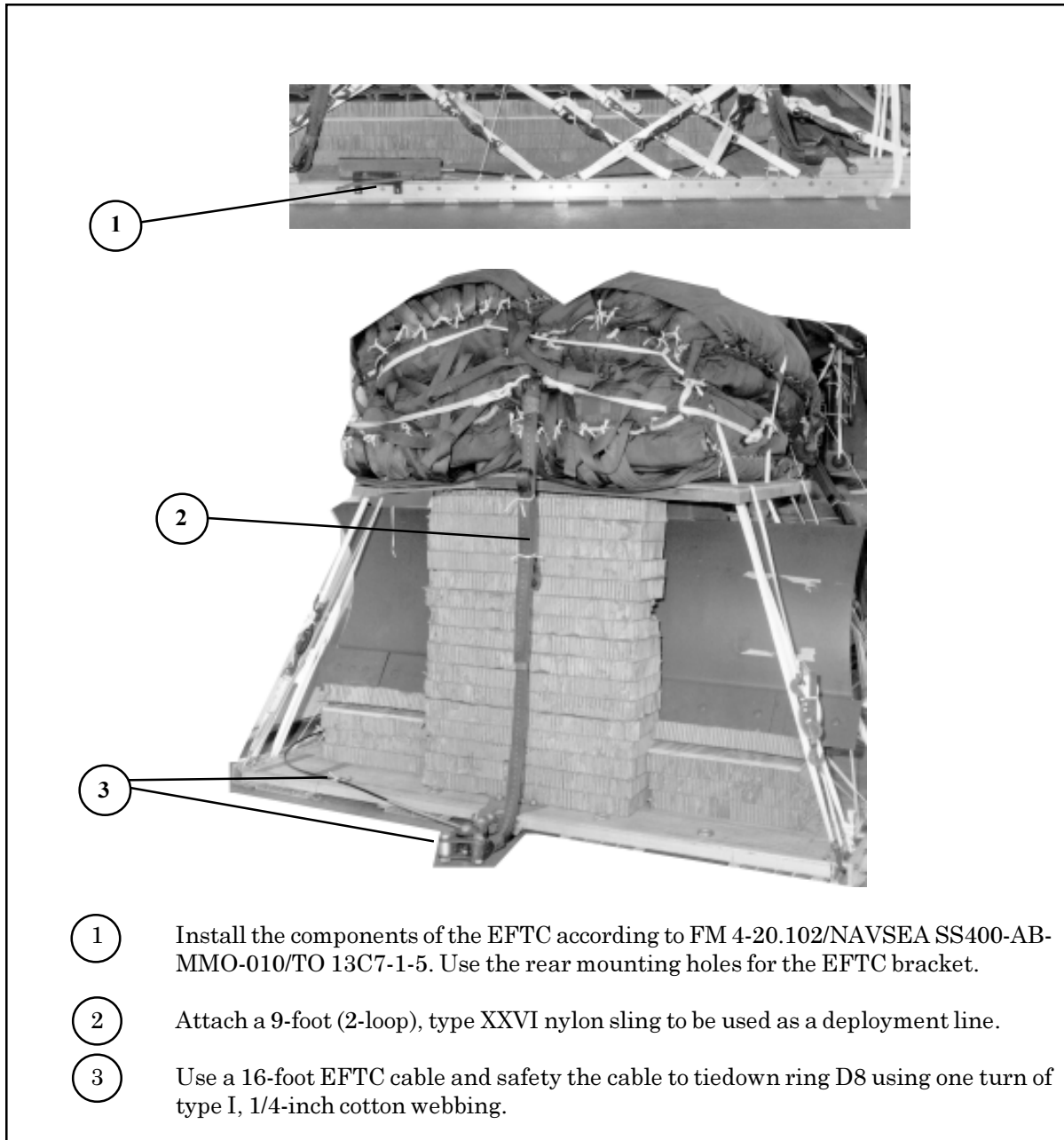

Figure 3-15. Extraction System Installed

INSTALLING PARACHUTE RELEASE

3-12. Prepare, attach, and safety an M2 release according to FM 4-20.102/NAVSEA SS400-AB-MMO-010/TO 13C7-1-5 and as shown in Figure 3-16.

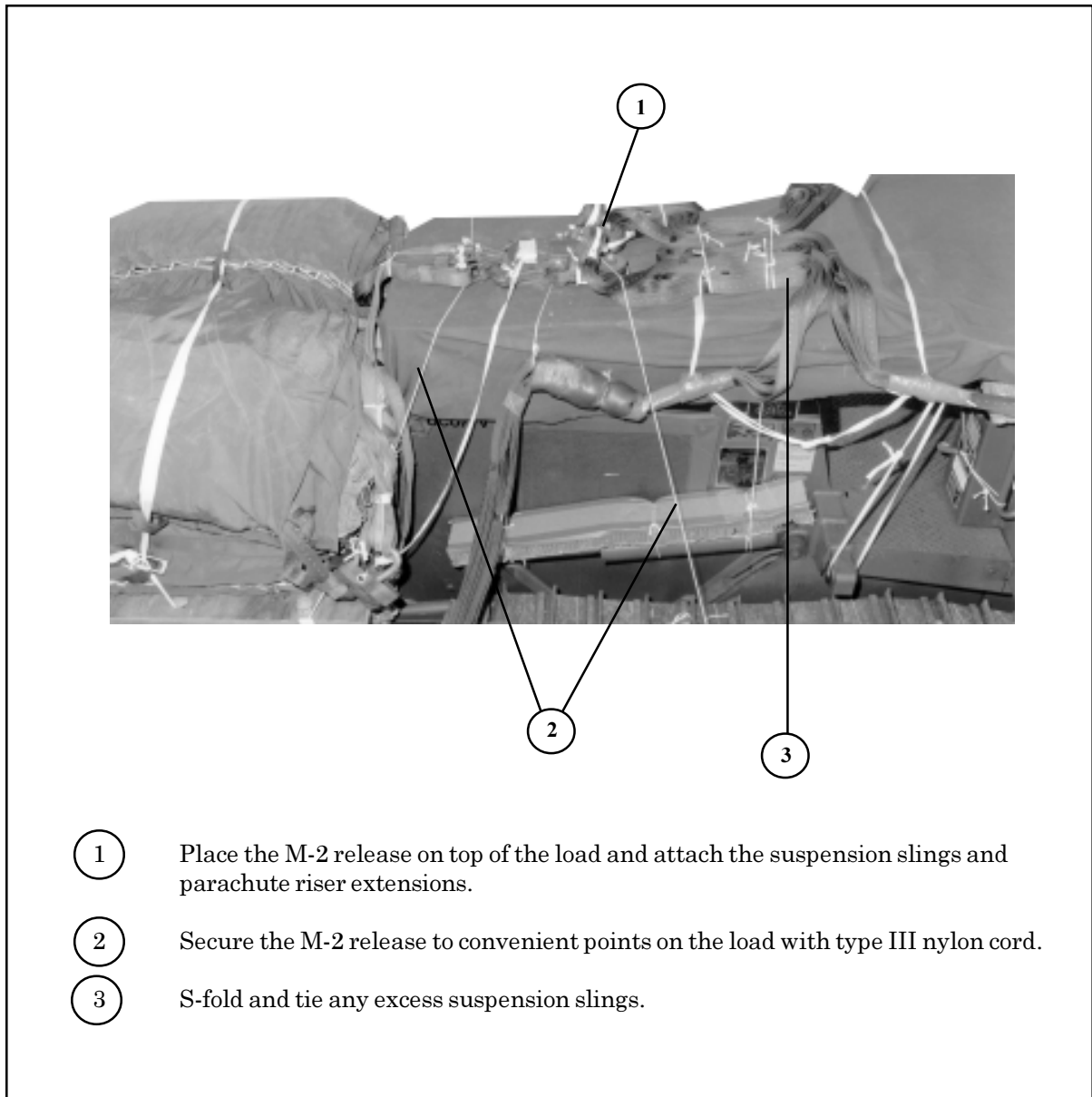

Figure 3-16. M-2 Cargo Release Installed

PLACING EXTRACTION PARACHUTE

3-13. Select the extraction parachute and extraction line needed using the extraction line requirements table in FM 4-20.102/NAVSEA SS400-AB-MMO-010/TO 13C7-1-5. Place the extraction parachute and line on the load for installation in the aircraft.

INSTALLING PROVISIONS FOR EMERGENCY RESTRAINTS

3-14. Select and install the provisions for the emergency aft restraints according to the emergency aft restraint requirements table in FM 4-20.102/NAVSEA SS400-AB-MMO-010/TO 13C7-1-5.

MARKING RIGGED LOAD

3-15. Mark the rigged load according to FM 4-20.102/NAVSEA SS400-AB-MMO-010/TO 13C7-1-5, and as shown in Figure 3-17. Complete Shipper's Declaration for Dangerous Goods. If the load varies from the one shown, the weight, height, CB, and parachute requirements must be recomputed.

EQUIPMENT REQUIRED

3-16. Use the equipment listed in Table 3-1 to rig this load.

CAUTION
**Make the final rigger inspection required by FM 4-20.102/NAVSEA-SS400-AB-
 MMO-010/TO 13C7-1-5 before the load leaves the rigging site.**

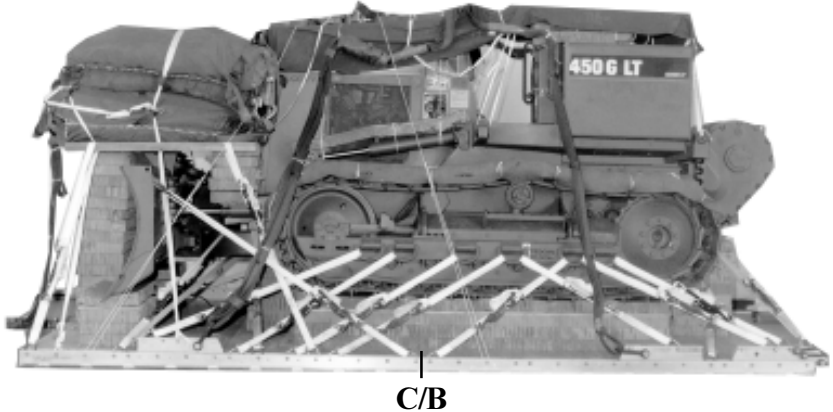

RIGGED LOAD DATA

Weight.....	20,960 pounds
Height.....	.94 inches
Width.....	108 inches
Length.....	215 inches
Overhang: Front.....	5 inches
Rear.....	18 inches
Center of Balance (CB) (from front edge of the platform).....	84 inches
Extraction System.....	EFTC

Figure 3-17. John Deere 450G Lt Full-Track Bulldozer Rigged on a 16-Foot Platform for Low-Velocity Airdrop

Table 3-1. Equipment Required for Rigging the John Deere 450G Lt Full-Track Commercial Bulldozer on a 16-foot, Type V Airdrop Platform for Low-Velocity Airdrop

National Stock Number	Item	Quantity
8040-00-273-8713	Adhesive, paste, 1-gal.	As required
4030-00-090-5354	Clevis, suspension, 1-in (large)	4
8305-00-880-8155	Cloth, coated (nyl, typeII, 17.0 oz, green, 60-in)	As required
4020-00-240-2146	Cord, nylon, type III, 550-lb.	As required
1670-00-434-5785	Coupling, airdrop extraction force transfer cable, 16-ft	1
	Cover:	
1670-00-360-0328	Clevis, large	1
8305-00-958-3685	Felt, 1/2-in thick	As required
1670-01-183-2678	Leaf, extraction line (line bag)	2
	Line extraction:	
1670-01-062-6313	60-ft (3-loop), type XXVI (for C-130)	1
1670-01-107-7651	140-ft (3-loop), type XXVI (for C-141,C-5 or C-17)	1
1670-01-064-4452	60-ft (1-loop), type XXVI with towplate link (for C-17)	1
1670-00-783-5988	Link assembly, type IV(C-17 only)	1
1670-00-753-3928	Pad, energy-dissipating, (honeycomb), 3- by 36- by 96-in:	22 sheets
	Parachute, cargo	
1670-01-016-7841	G-11B	4
	Parachute, cargo extraction	
1670-00-040-8135	28-ft	1
1670-01-063-3715	15-ft drogue (for C-17)	1
	Platform, airdrop, type V, 16-ft:	
1670-01-162-2372	Clevis, assembly (type V)	(30)
1670-01-162-2376	Extraction bracket assembly	(1)
1670-01-162-2381	Tandem link assembly (Multipurpose link)	(2)
	Platform, stowage:	
5510-00-220-6148	Lumber, 2- by 6- by: 48-in	(2)
	85-in	(2)
5530-00-128-4981	Plywood, 3/4-in:	4 sheets

Table 3-1. Equipment Required for Rigging the John Deere 450G Lt Full-Track Commercial Bulldozer on a 16-foot, Type V Airdrop Platform for Low-Velocity Airdrop (Continued)

National Stock Number	Item	Quantity
1670-01-097-8817	Release, cargo parachute, M-2	1
	Sling, cargo, airdrop:	
1670-01-062-6304	9-ft (2-loop), type XXVI	1
1670-01-062-6305	9-ft (4-loop), type XXVI	2
1670-01-062-6307	12-ft (4-loop), type XXVI	4
5340-01-062-6308	16-ft (4-loop), type XXVI	4
1670-00-040-8219	Strap, parachute release with fastener and knife	2
7501-00-266-5016	Tape, adhesive, 2-in	As required
1670-00-937-0271	Tiedown assembly, 15-ft	30
1670-01-483-8259	Towplate release mechanism (H-block) (C-17 only)	1
	Webbing:	
8305-00-268-2411	Cotton, 1/4-inch, type I	As required
8305-00-082-5752	Nylon, tubular 1/2-in	As required

Chapter 4

RIGGING THE DEPLOYABLE UNIVERSAL COMBAT EARTHMOVER (DEUCE) ON A 24-FOOT, TYPE V PLATFORM FOR LOW-VELOCITY AIRDROP

DESCRIPTION OF LOAD

4-1. The Deployable Universal Combat Earthmover (DEUCE), Figure 4-1, is rigged on a 24-foot type V airdrop platform with eight G-11 cargo parachutes. The unrigged DEUCE weighs 35,000 pounds. It is 112 inches high reducible to 90 inches in the kneeling position for airdrop. The rigged load is 310 inches long, 101 1/2 inches high and 110 inches wide.

PREPARING PLATFORM

4-2. Prepare a 24-foot, type V airdrop as shown in Figure 4-2.

Note: Remove the cab for airdrop.

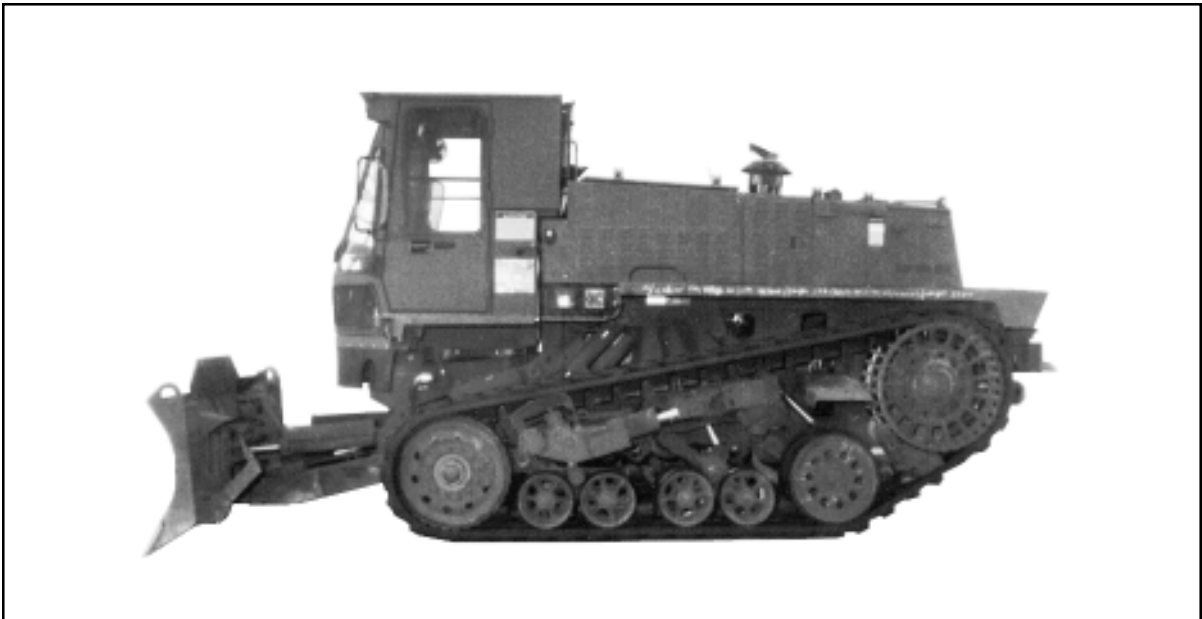
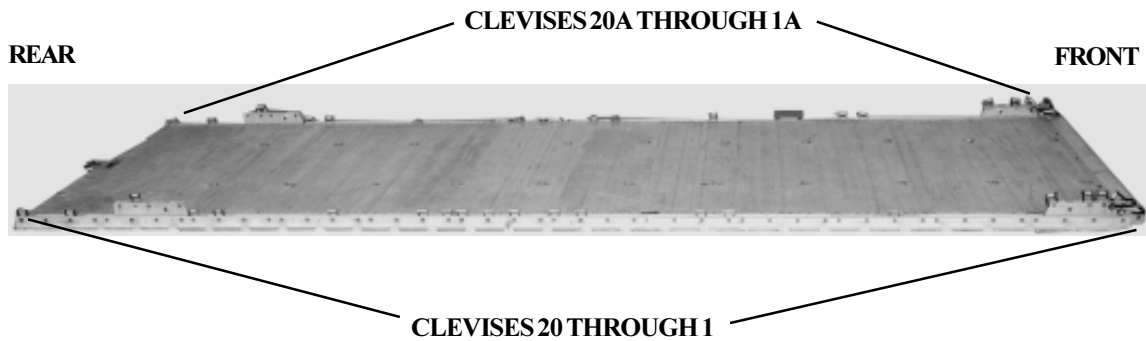

Figure 4-1. Deployable Universal Combat Earthmover (DEUCE)



Step:

1. Inspect, or assemble and inspect, a 24-foot, type V airdrop platform as outlined in TM 10-1670-268-20&P/TO 13C7-52-22.
2. Install a tandem link to the front of each platform side rail using holes 1, 2, and 3.
3. Install a suspension link to the right and left platform side rails using holes 41, 42, and 43. The links are required to lift the load after rigging is completed.
4. Install a clevis on bushings 1, 2, 3, and 4 of each tandem link.
5. Install a clevis on bushing 3 of each suspension link.
6. Starting at the front of the right platform side rail, install clevises on the bushings bolted to holes 10, 17, 18, 23, 24, 26, 27, 28, 29, 30, 34, 39, 40, 46, and 48.
7. Starting at the front of the left platform side rail, install clevises on the bushings bolted to holes 10, 11, 18, 23, 24, 26, 27, 28, 29, 30, 34, 39, 40, 46, and 48.
8. Starting at the front of the platform, number the clevises 1 through 20 on the right side and 1A through 20A on the left side.
9. Label the tiedown rings according to FM 4-20.102/NAVSEA SS400-AB-MMO-010/TO 13C7-1-5.

Figure 4-2. Platform Prepared

BUILDING AND POSITIONING HONEYCOMB STACKS

4-3. Build the honeycomb stacks as shown in Figures 4-3 through 4-6. Position the stacks as shown in Figure 4-7.

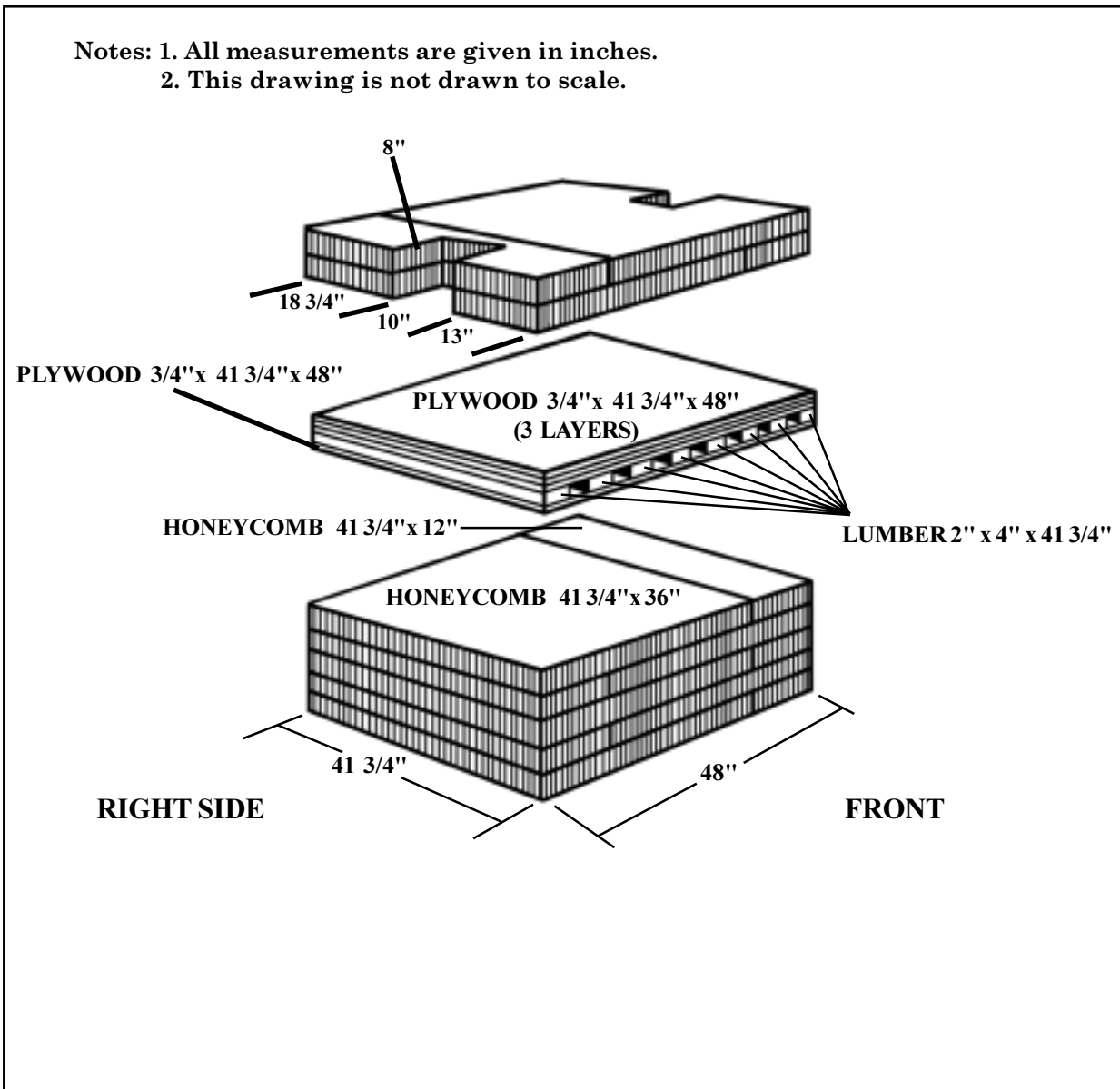

Figure 4-3. Honeycomb Stack 1 Prepared

Stack Number	Pieces	Width (Inches)	Length (Inches)	Material	Instructions
1	5	36	41 3/4	Honeycomb	Alternate and glue the 41 3/4-inch by 36-inch piece with the 41 3/4-inch by 12-inch piece to form a base.
	5	12	41 3/4	Honeycomb	
	4	48	41 3/4	3/4-inch Plywood 2-inch by 4-inch Lumber	Place and nail a 2-inch by 4-inch piece of lumber flush on each 41 3/4-inch side of a piece of plywood. Place and nail the remaining six pieces of 2-inch by 4-inch lumber, 3 inches apart from each other, to the plywood. Place and nail the remaining three pieces of plywood on top of and flush with the 2-inch by 4-inch pieces of lumber. Glue the plywood and lumber on top of the honeycomb base.
	8		41 3/4		
	2	36	41 3/4	Honeycomb	Alternate and glue the 41 3/4-inch by 36-inch pieces and the 41 3/4-inch by 12-inch pieces together. Make a 10-inch long by 8-inch deep cutout on each 41 3/4-inch side, 13 inches from the front edge. Glue the honeycomb on top of and flush with the plywood.
	2	12	41 3/4	Honeycomb	

Figure 4-3. Honeycomb Stack 1 Prepared (Continued)

- Notes: 1. All measurements are given in inches.
 2. This drawing is not drawn to scale.

TOP VIEW (TWO LAYERS OF HONEYCOMB)

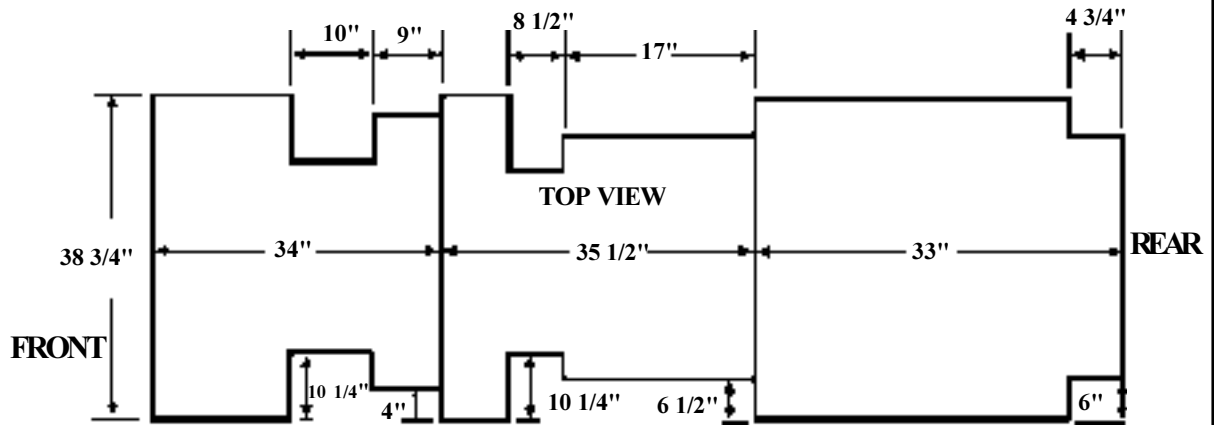

PLYWOOD 3/4"x 38 3/4"x 51 1/4"
 TWO PIECES PLACED END TO END

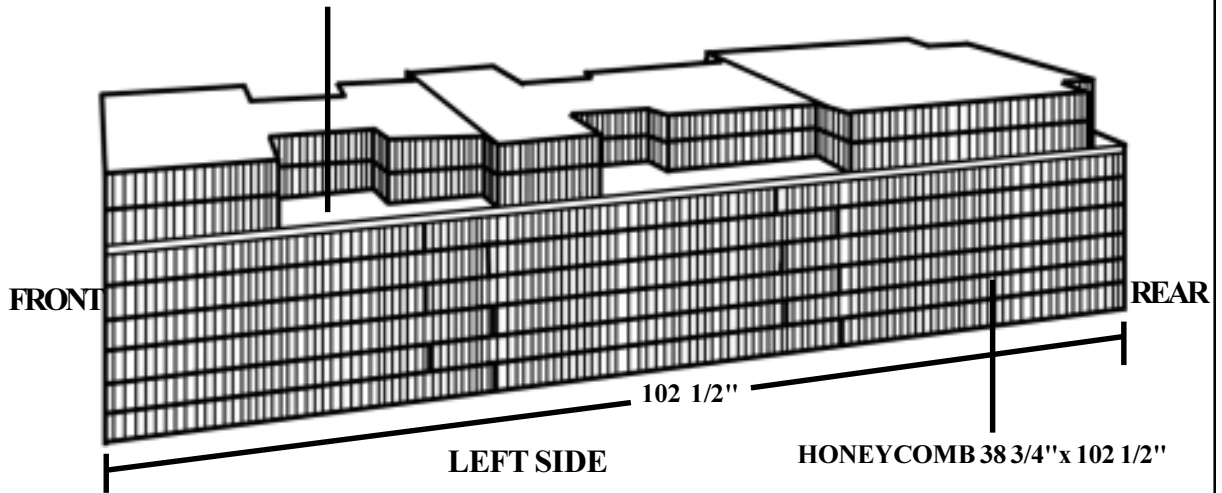

Figure 4-4. Honeycomb Stack 2 Prepared

Stack Number	Pieces	Width (Inches)	Length (Inches)	Material	Instructions
2	12 6	38 3/4 38 3/4	36 30 1/2	Honeycomb Honeycomb	Place a 30 1/2-inch by 38 3/4-inch piece of honeycomb beside two pieces of 36-inch by 38 3/4-inch honeycomb forming a 38 3/4-inch by 102 1/2-inch layer. Alternate the pieces in the following layers to form a base six layers high. Glue all layers together.
	2	38 3/4	51 1/4	3/4-inch Plywood	Place and glue the plywood end to end on top of the honeycomb base.
	2	38 3/4	33	Honeycomb	Cut a notch 4 3/4-inches long by 6 inches deep on each corner of one 38 3/4-inch side of each piece of honeycomb. Align the notches and glue the layers together. Glue the honeycomb to the plywood with the notches facing rear.
	2	38 3/4	35 1/2	Honeycomb	Cut a notch 17-inches long by 6 1/2 inches deep along each 35 1/2-inch side of each piece of honeycomb measured from the rear. Cut a second notch 8 1/2 inches long by 10 1/4 inches deep on both sides of both pieces of honeycomb measured from the front of the first notch. Align the notches and glue the honeycomb pieces together. Glue the honeycomb to the plywood with the notches facing rear and against the previously placed stack.
	2	38 3/4	34	Honeycomb	Cut a notch 9 inches long by 4 inches deep along each 34-inch side of each piece of honeycomb measured from the rear. Cut a second notch 10 inches long by 10 1/4 inches deep on both sides of both pieces of honeycomb measured from the front of the first notch. Align the notches and glue the honeycomb pieces together. Glue the honeycomb to the plywood with the notches facing rear and against the previously placed stack.

Figure 4-4. Honeycomb Stack 2 Prepared (Continued)

Stack Number	Pieces	Width (Inches)	Length (Inches)	Material	Instructions
3	4	48	16 1/2	Honeycomb	Alternate and glue the 48-inch by 36-inch piece with the 48-inch by 16 1/2-inch piece to form a 48-inch by 52 1/2-inch base.
	4	48	36	Honeycomb	
	2	48	52 1/2	3/4-inch Plywood	Place and nail a 4 by 4 piece of lumber flush on each 48-inch side of a piece of plywood. Place and nail to the plywood the remaining three pieces of 4 by 4 lumber 8 3/4 inches apart.
	5	48		4 by 4 Lumber	
	8	51	2 3/4 to 21 1/4	3/4-inch Plywood	Cut eight 3/4-inch plywood sideboards as shown in Figure 4-5.
	2		2 3/4	4 by 4 Lumber	Nail the 4 by 4 piece of lumber to the sideboards using the dimensions shown in Figure 4-5. There are two layers of plywood on each side.
	2		7	4 by 4 Lumber	
	2		11 1/4	4 by 4 Lumber	
	2		15 3/4	4 by 4 Lumber	
	2		20	4 by 4 Lumber	
1			21 1/4	3/4-inch Plywood	Nail to the sideboards and 4 by 4 piece of lumber with a 1 1/2-inch overhang on each end.
1		48	2 3/4	3/4-inch Plywood	Nail to the sideboards and 4 by 4 piece of lumber with a 1 1/2" overhang on each end.
					Nail the remaining 48-inch by 52 1/2-inch piece of plywood to the sideboards and 4 by 4 piece of lumber ensuring all sides are flush. Nail this assembly to the 3/4-inch plywood with five 4 by 4 pieces of lumber built above. Glue the wooden assembly to the 48-inch by 52 1/2-inch honeycomb base.

Figure 4-5. Honeycomb Stack 3 Prepared (Continued)

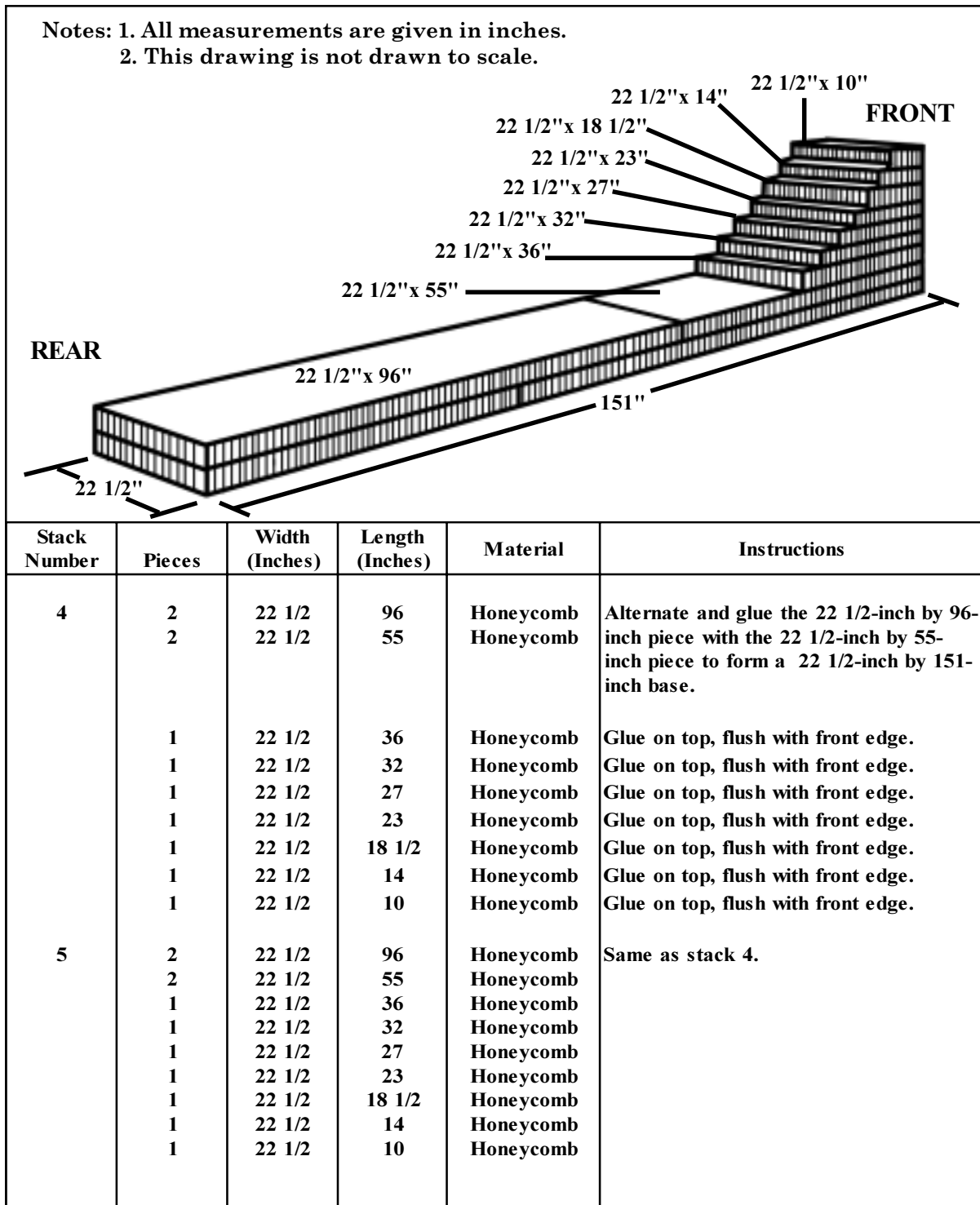

Figure 4-6. Honeycomb Stacks 4 and 5 Prepared

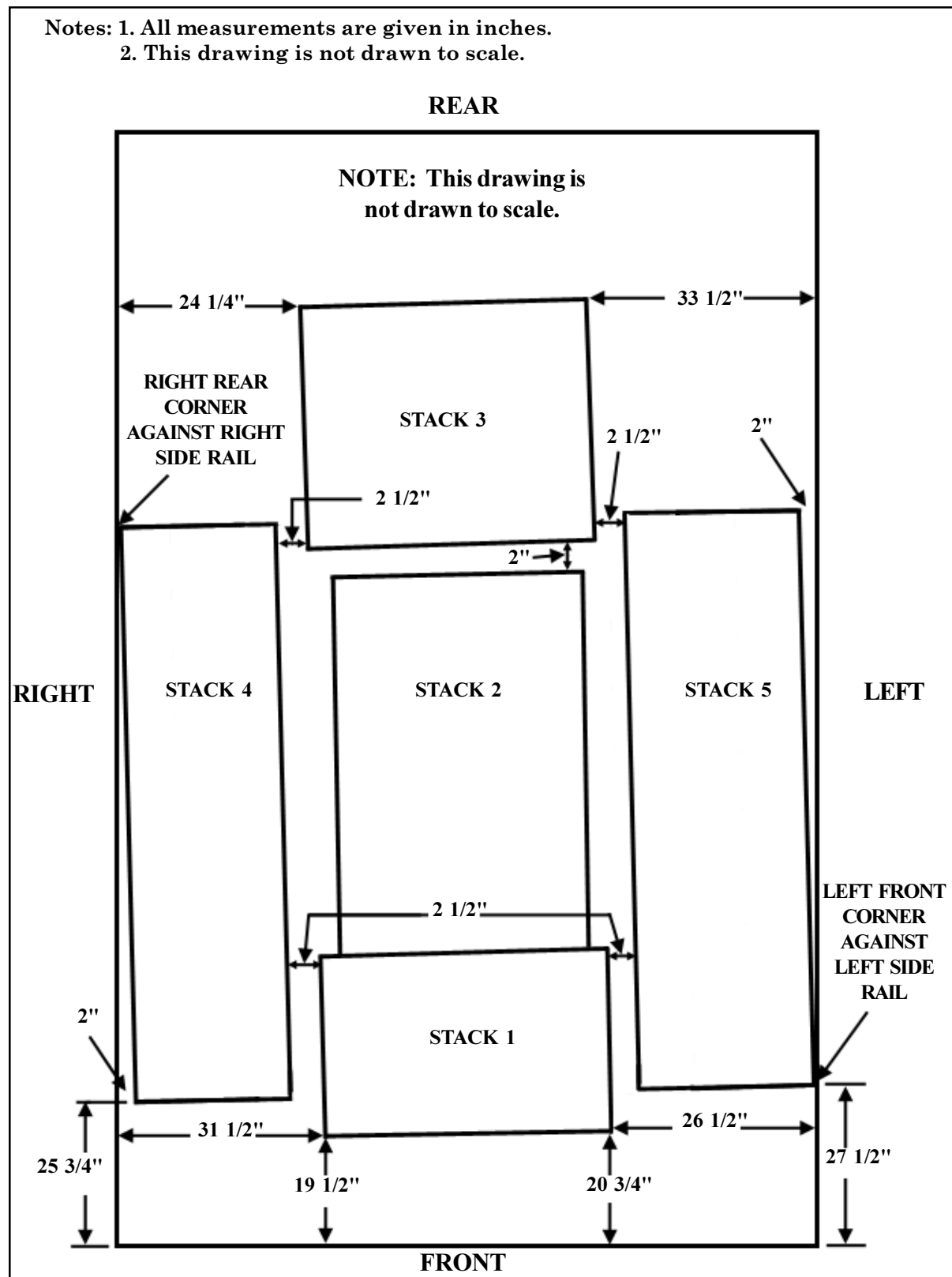

Figure 4-7. Honeycomb Stacks Positioned on Platform

Step:

1. Position stack 1 with the right front corner 19 1/2 inches from the front edge of the platform and 31 1/2 inches from the right side rail. The left front corner is 20 3/4 inches from the front of the platform and 26 1/2 inches from the left side rail.
2. Position stack 2 centered on and flush with stack 1 maintaining the same angle as stack 1.
3. Position stack 3 with the front edge 2 inches from the rear edge of stack 2. The right rear corner is 24 1/2 inches from the right side rail and the left rear corner is 33 1/2 inches from the left side rail.
4. Position stack 4 with the right front corner 25 3/4 inches from the front edge of the platform and the right rear corner against the right side rail. Maintain the same angle as stacks 1 and 2.
5. Position stack 5 with the left front corner 27 1/2 inches from the front edge of the platform and against the left side rail. Maintain the same angle as stacks 1 and 2.

Figure 4-7. Honeycomb Stacks Positioned on Platform (Continued)

PREPARING THE DEUCE

4-4. Prepare the DEUCE as described below.

a. Check the fuel level. Make sure the fuel tank is no less than 1/2 and not more than 3/4 full.

b. Prepare the DEUCE.

(1) Remove the cab.

(2) Prepare the DEUCE as shown in Figure 4-8.

Note: The owning unit must provide maintenance personnel operators to remove components at the rigging site.

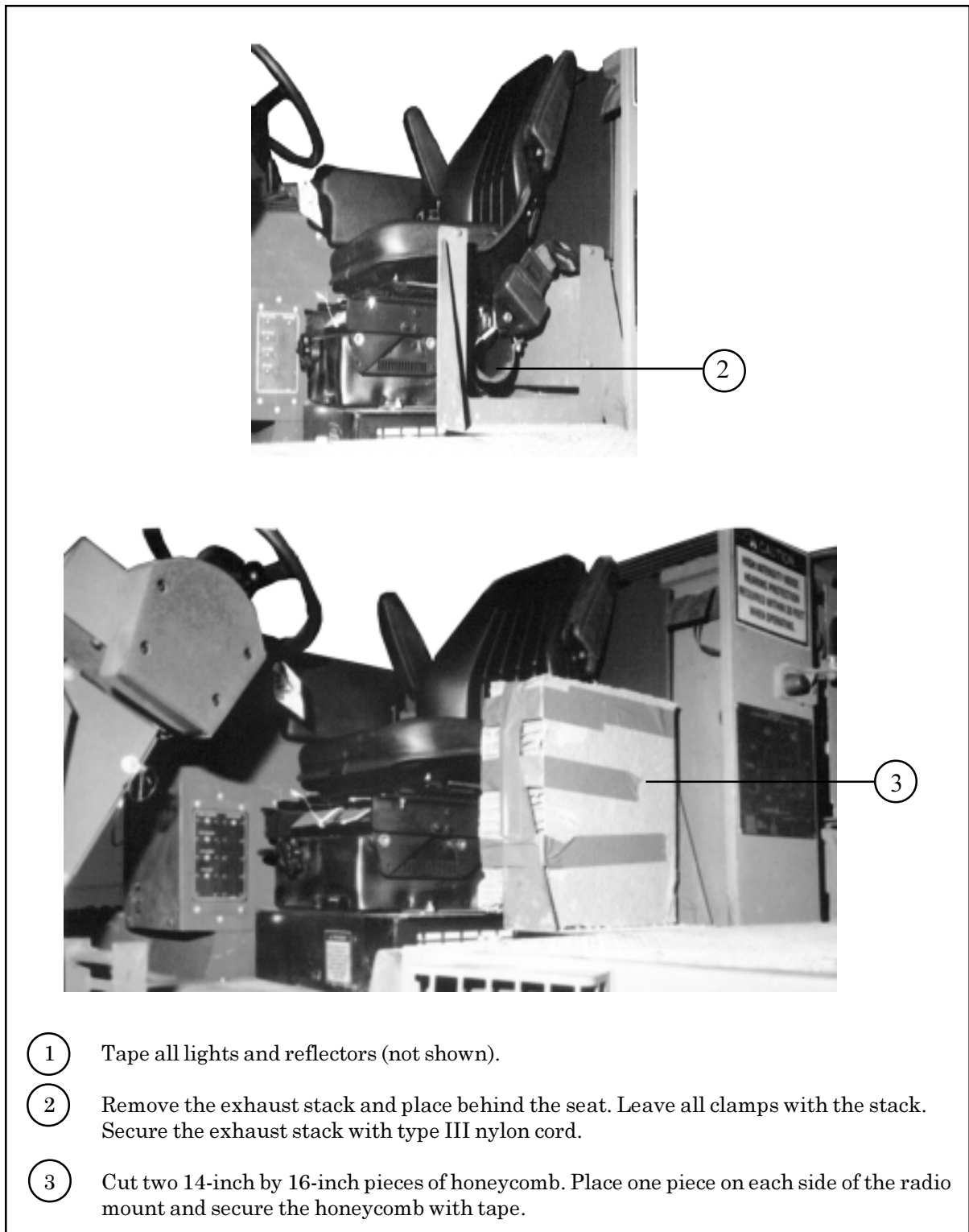
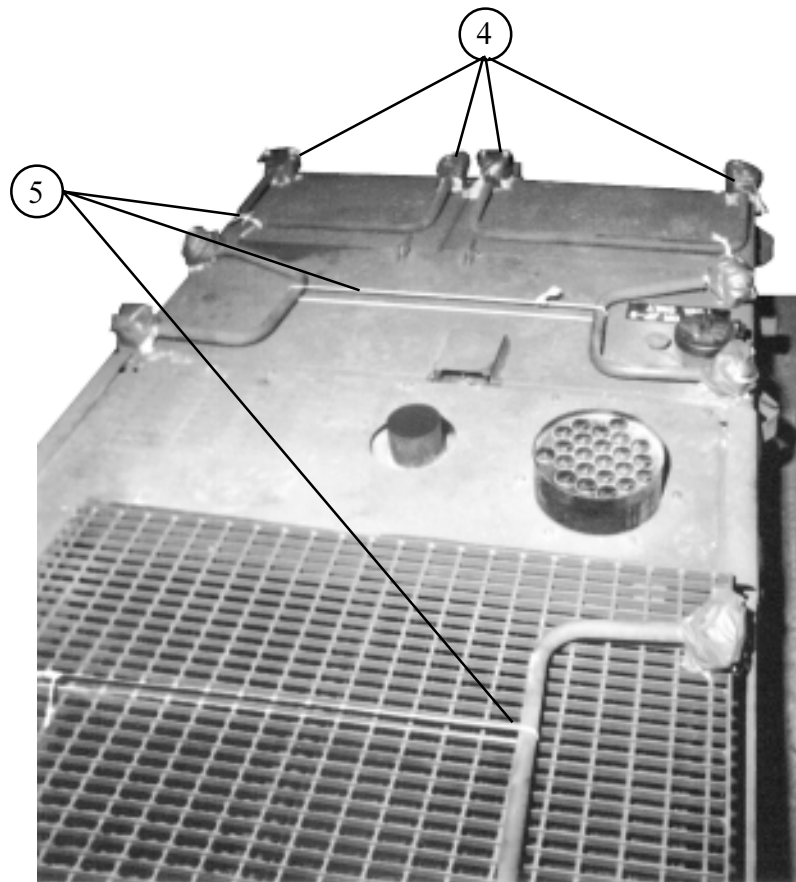

Figure 4-8. DEUCE Prepared



- ④ Pad all brackets on the engine compartment with cellulose padding. Secure the padding with tape.
- ⑤ Safety tie the grab rails together or to the body with type III nylon cord.

Note: Tape the exhaust outlet with 2-inch adhesive tape. (Not shown)

Figure 4-8. DEUCE Prepared (Continued)

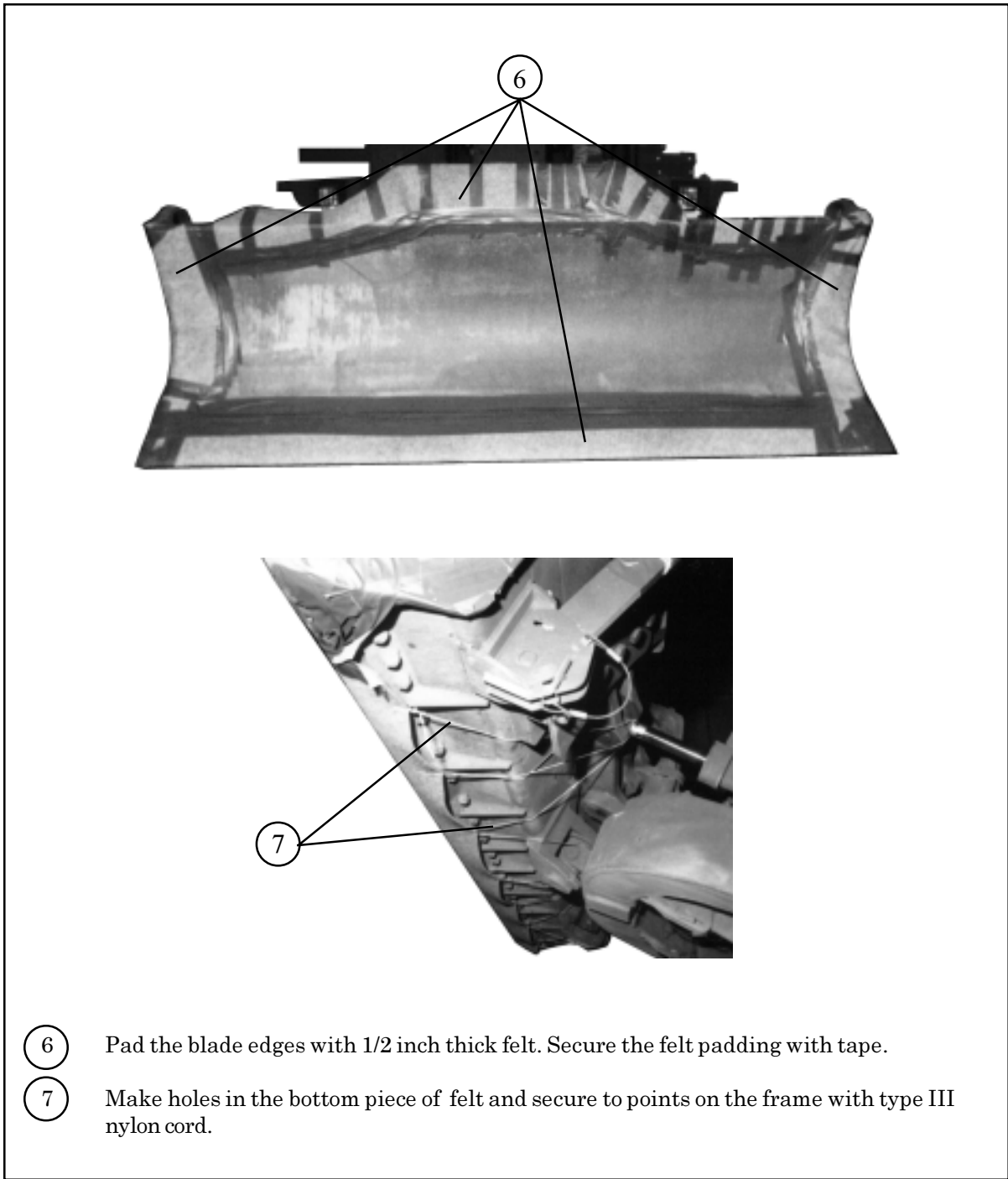

- ⑥ Pad the blade edges with 1/2 inch thick felt. Secure the felt padding with tape.
- ⑦ Make holes in the bottom piece of felt and secure to points on the frame with type III nylon cord.

Figure 4-8. DEUCE Prepared (Continued)

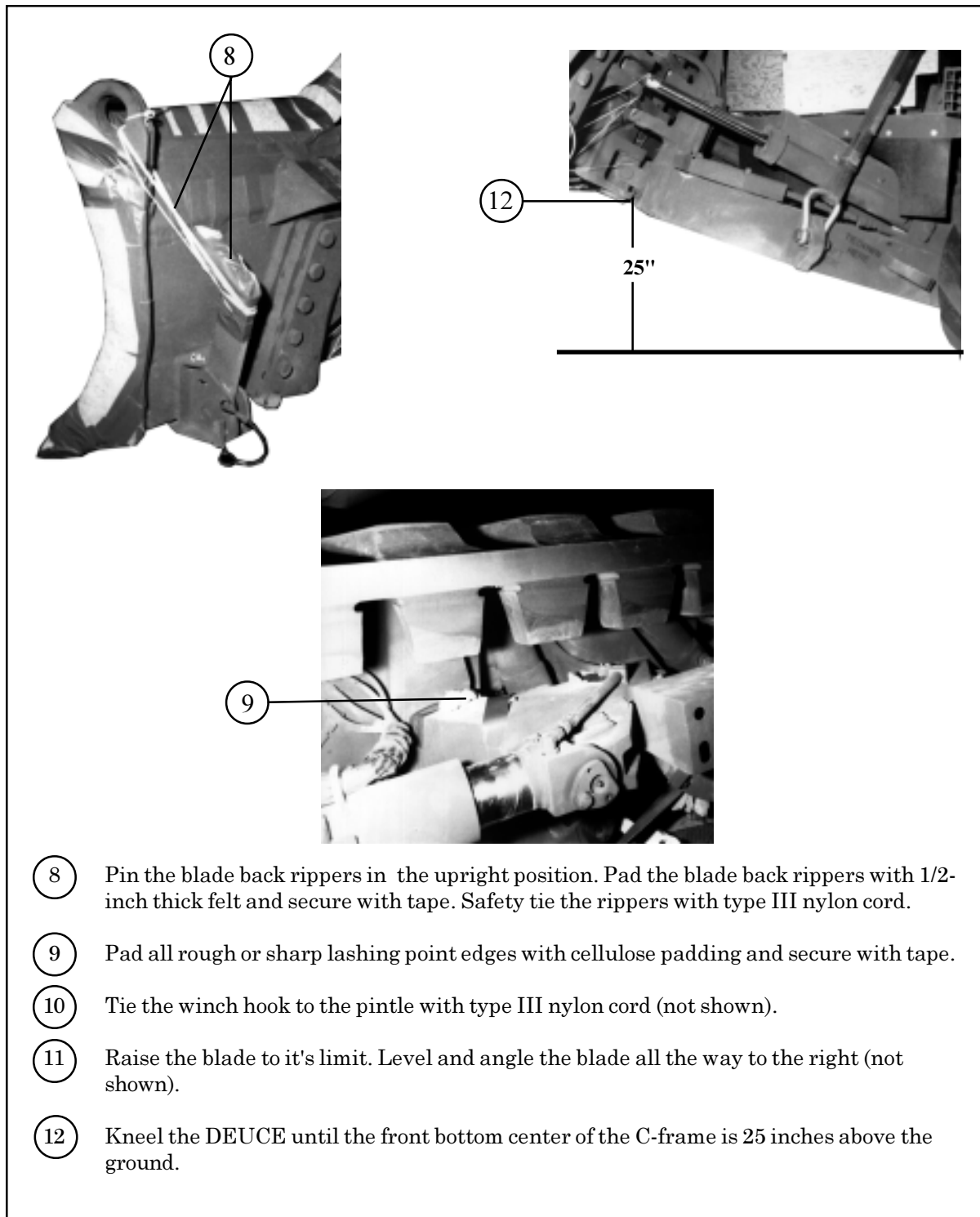

Figure 4-8. DEUCE Prepared (Continued)

LIFTING AND POSITIONING THE DEUCE

4-5. Lift and position the DEUCE as shown in Figure 4-9.

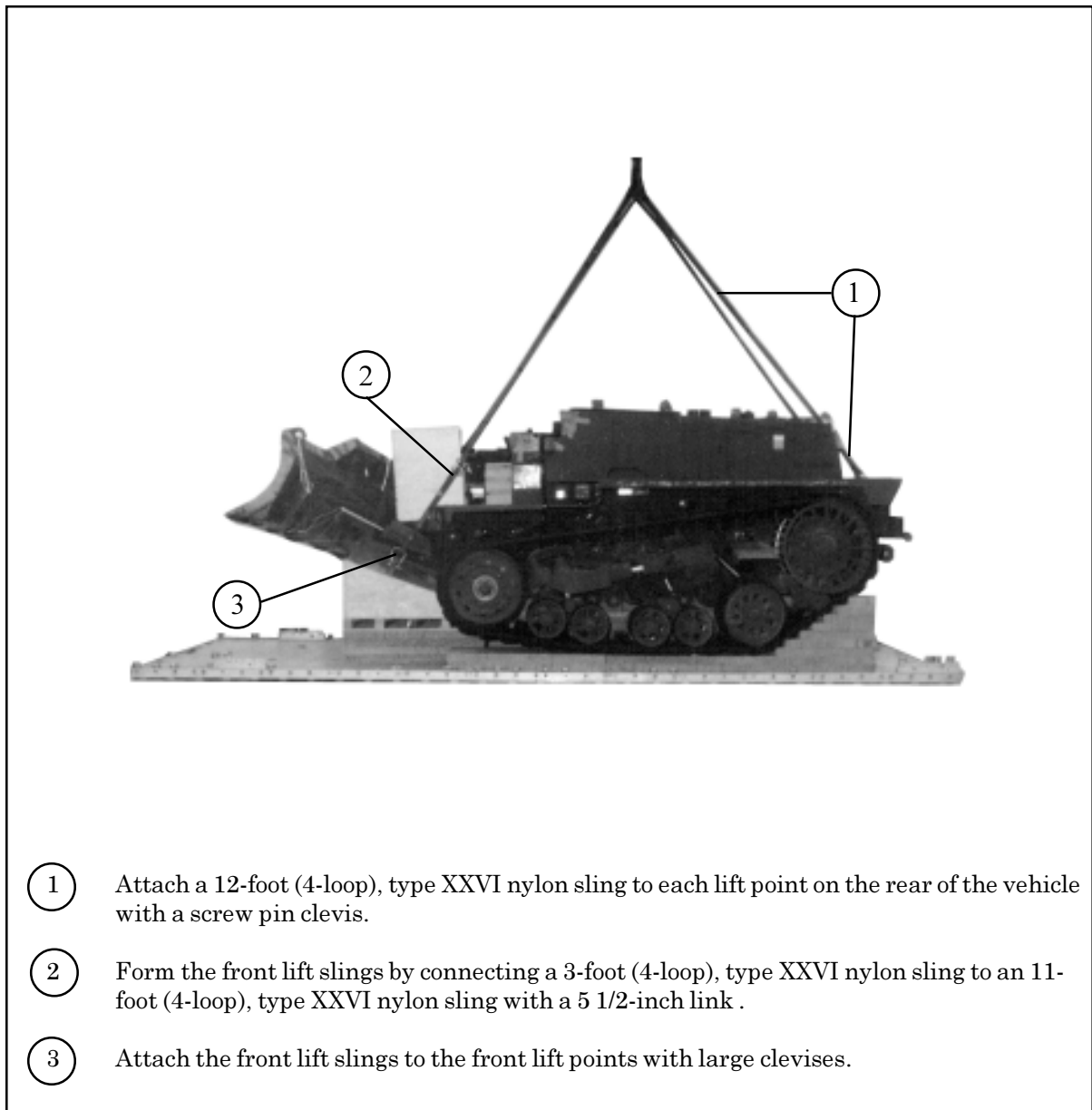

Figure 4-9. DEUCE Lifted and Positioned on Platform

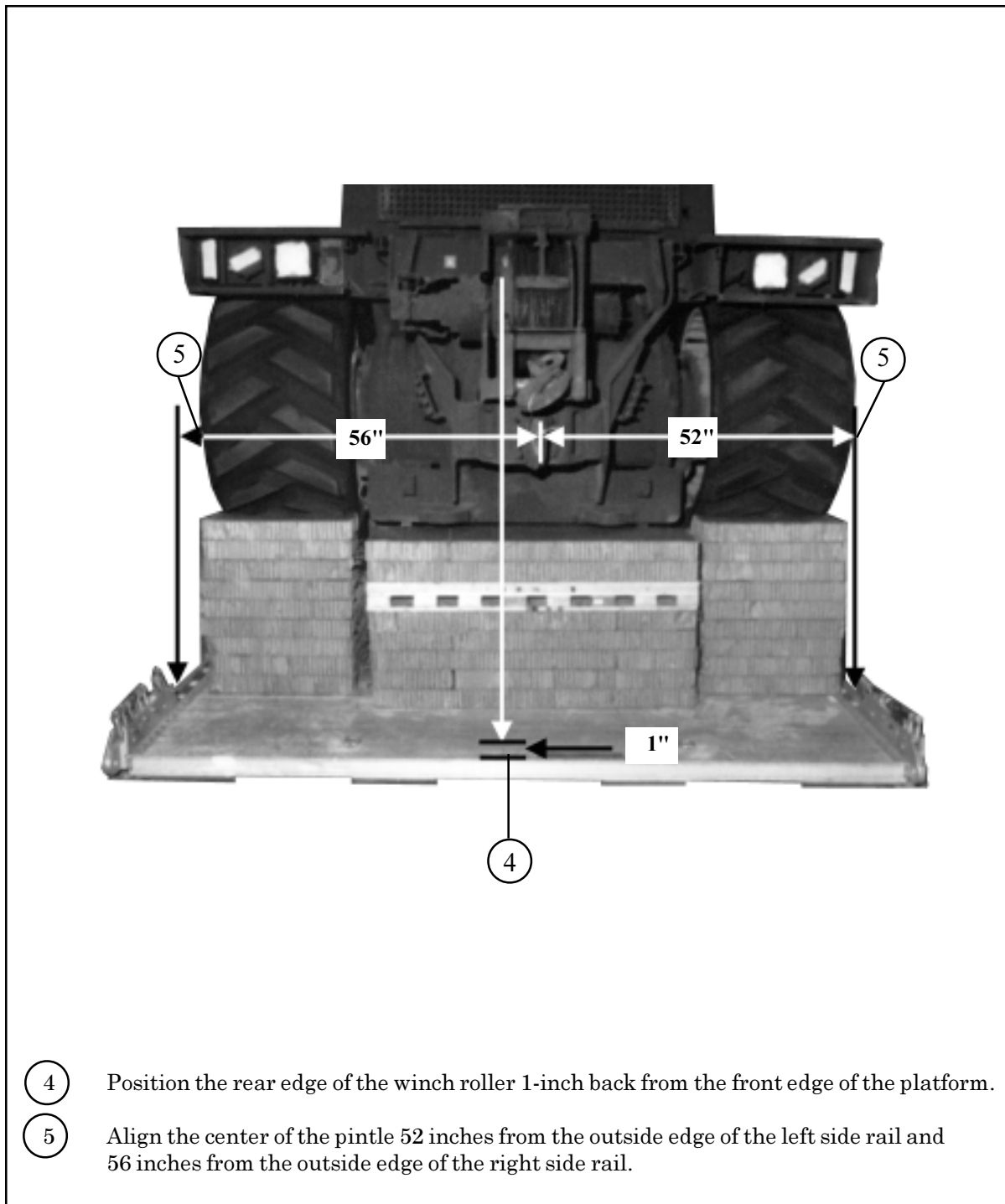
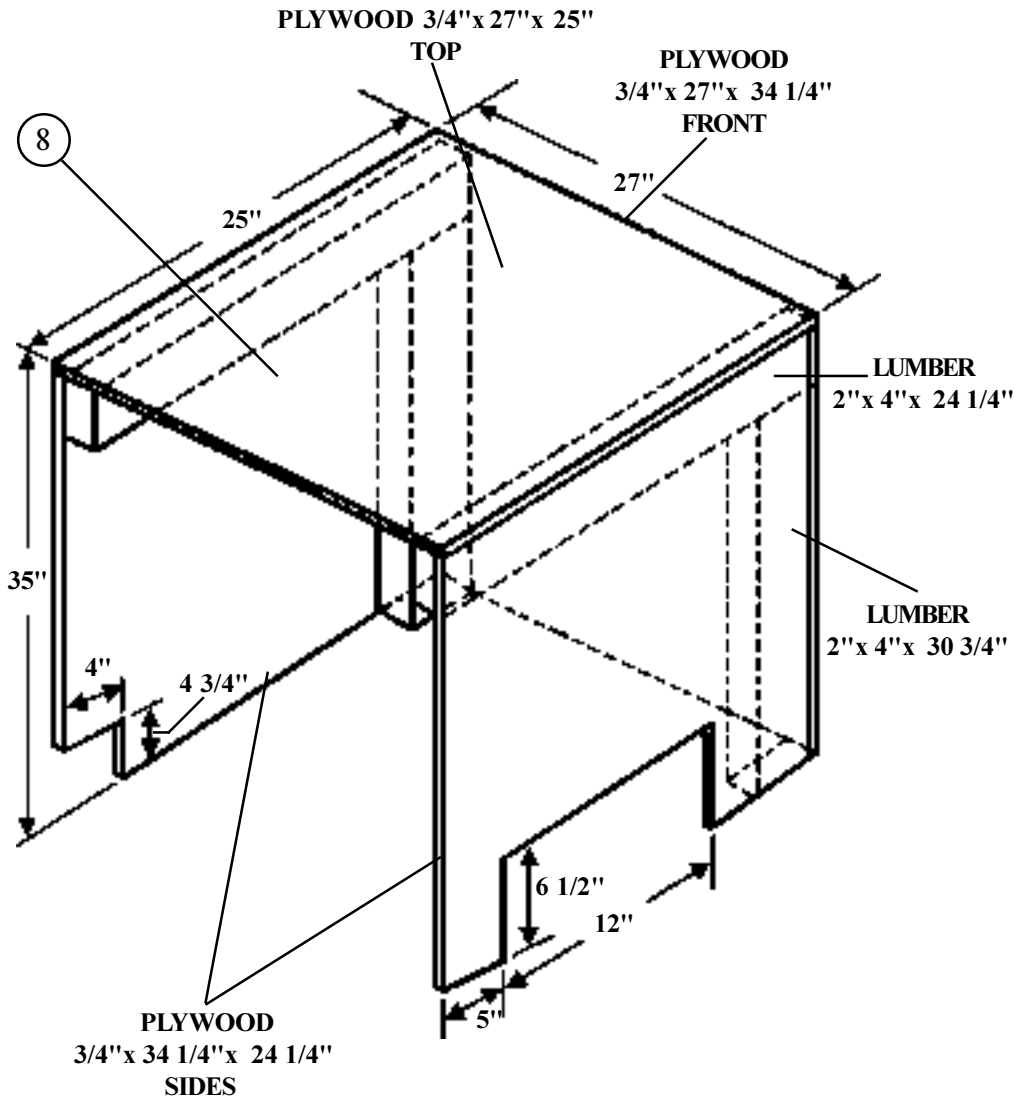

Figure 4-9. DEUCE Lifted and Positioned on Platform (Continued)

- Notes: 1. All measurements are given in inches.
 2. This drawing is not drawn to scale.



- 8 Construct and nail a box according to the diagram shown above.

Figure 4-9. DEUCE Lifted and Positioned on Platform (Continued)

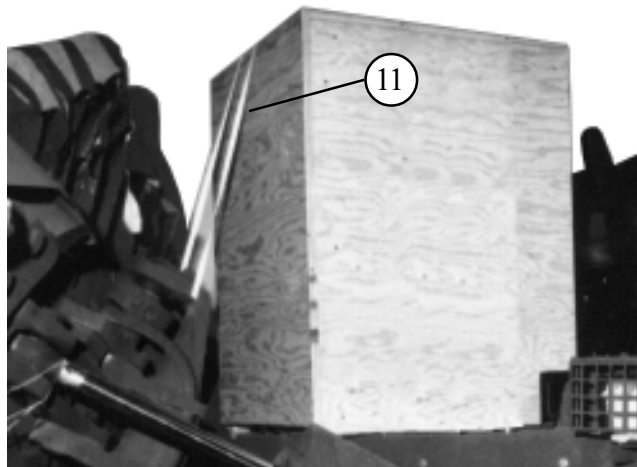
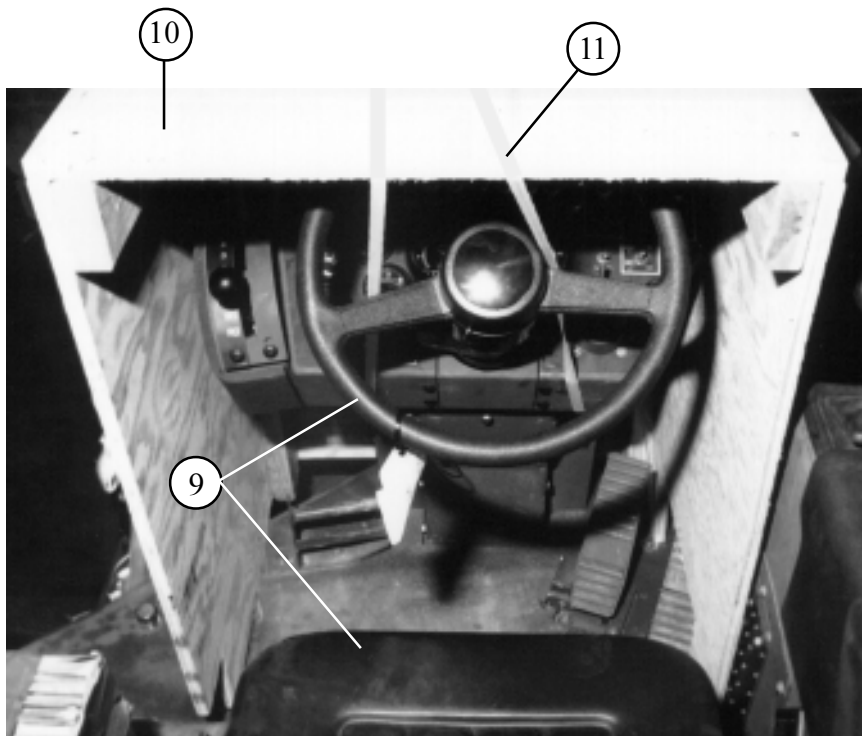

- ⑨ Tilt and lock the steering wheel and compress the seat in the down position.
- ⑩ Place the box over the steering wheel and column.
- ⑪ Secure the box with 1/2-inch tubular nylon routed around the steering wheel column, over the box, and tie to the blade pivot point.

Figure 4-9. DEUCE Lifted and Positioned on Platform (Continued)

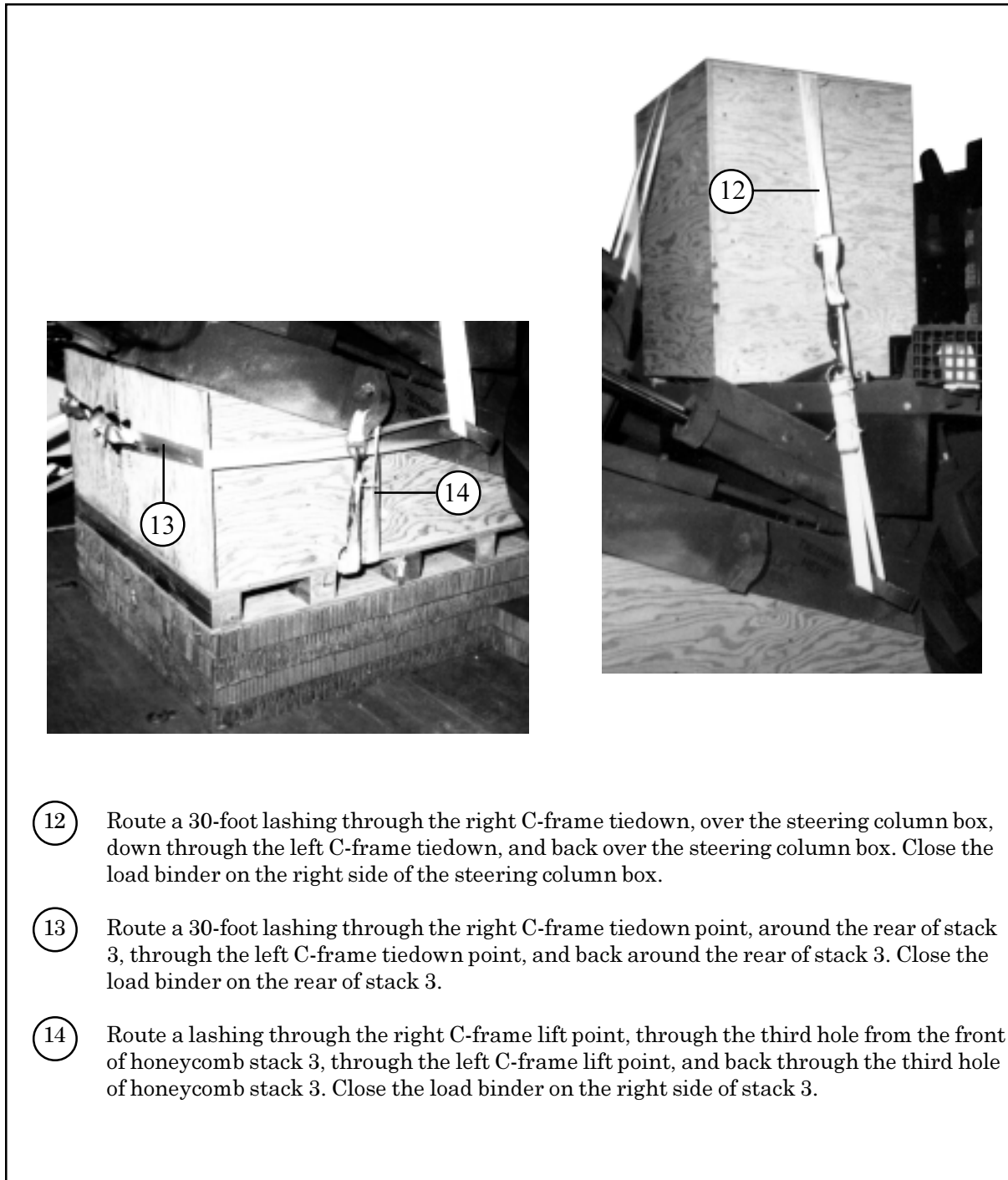
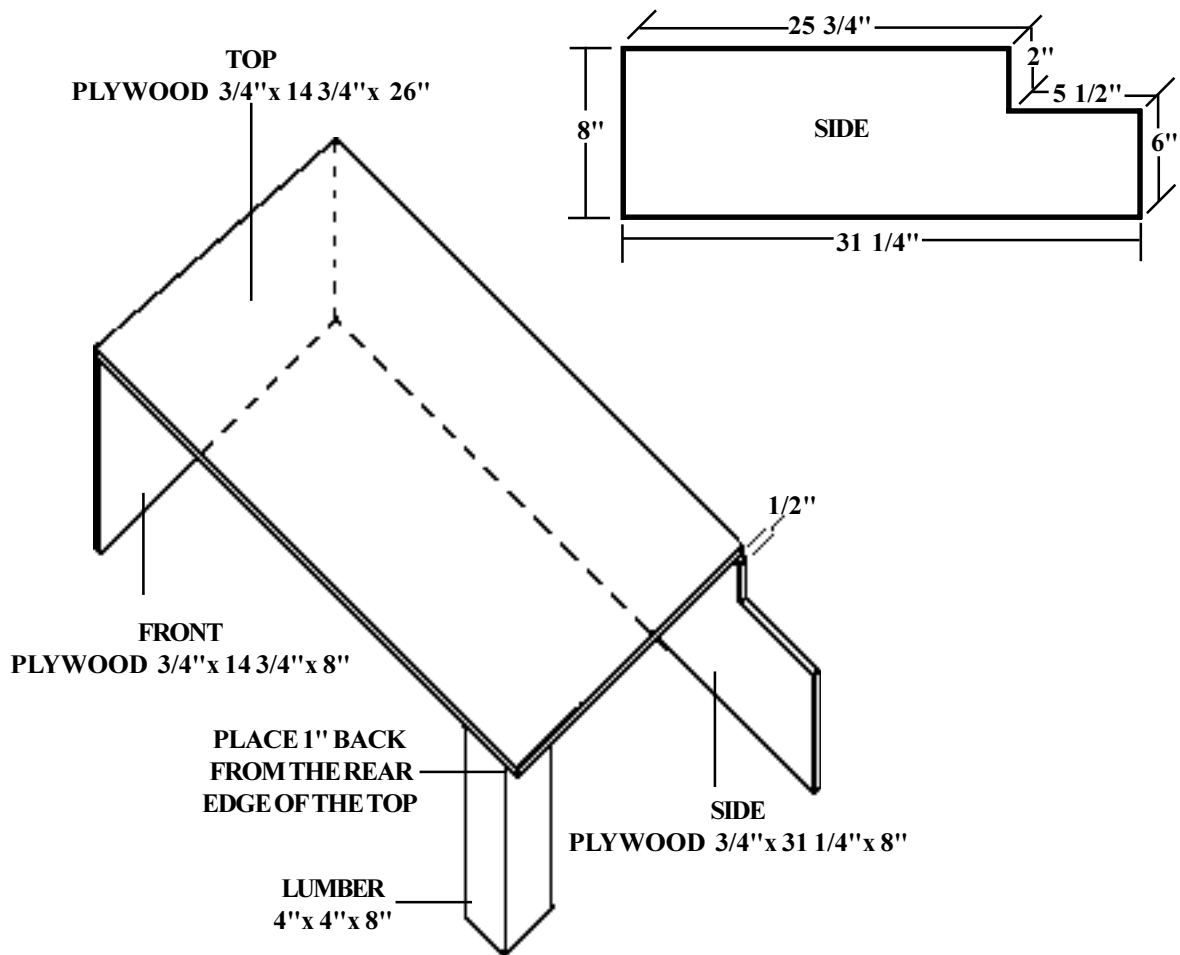

Figure 4-9. DEUCE Lifted and Positioned on Platform (Continued)

Notes: 1. All measurements are given in inches.
 2. This drawing is not drawn to scale.



- 15 Construct and nail the blade control lever box as shown above.

Figure 4-9. DEUCE Lifted and Positioned on Platform (Continued)

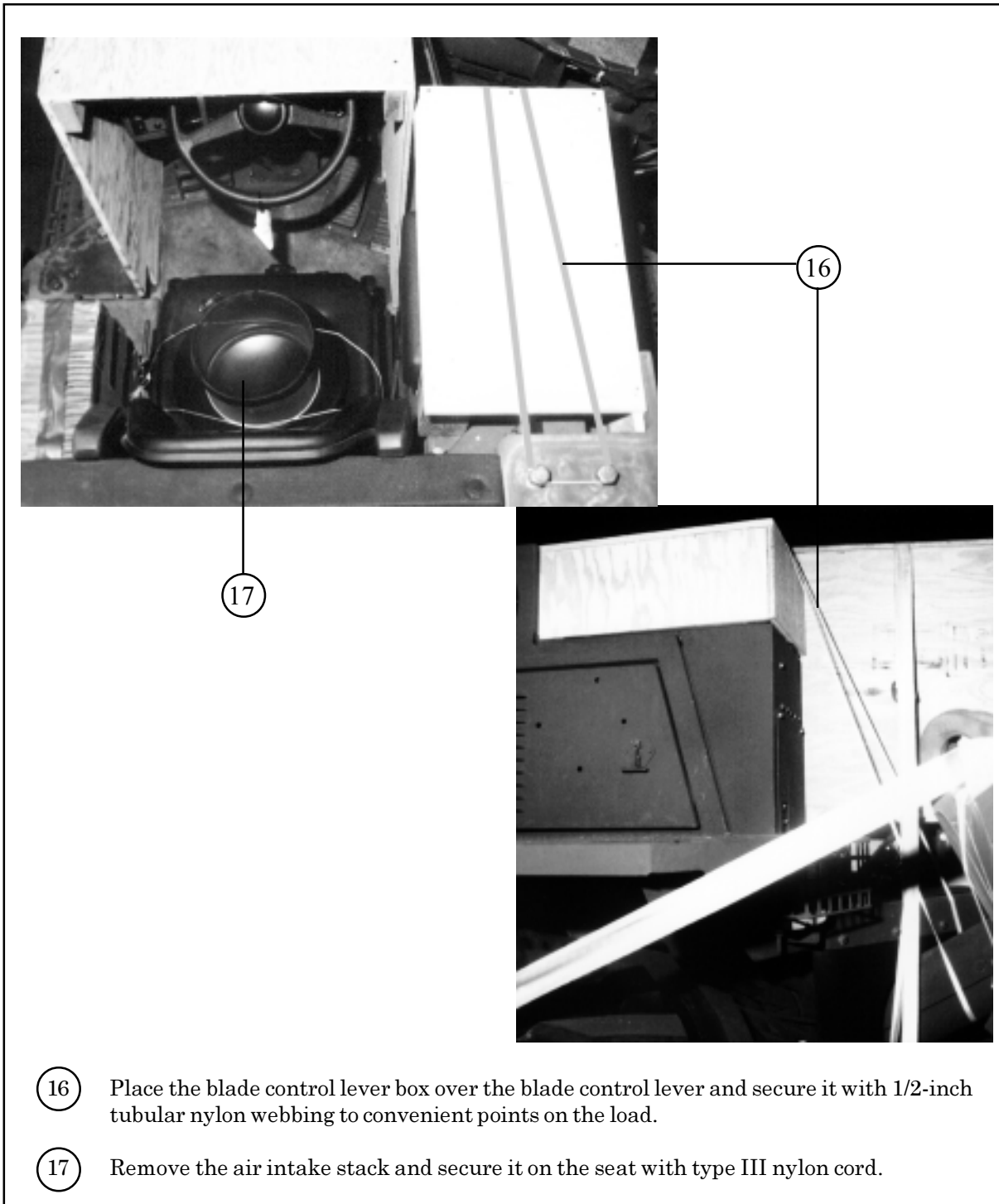
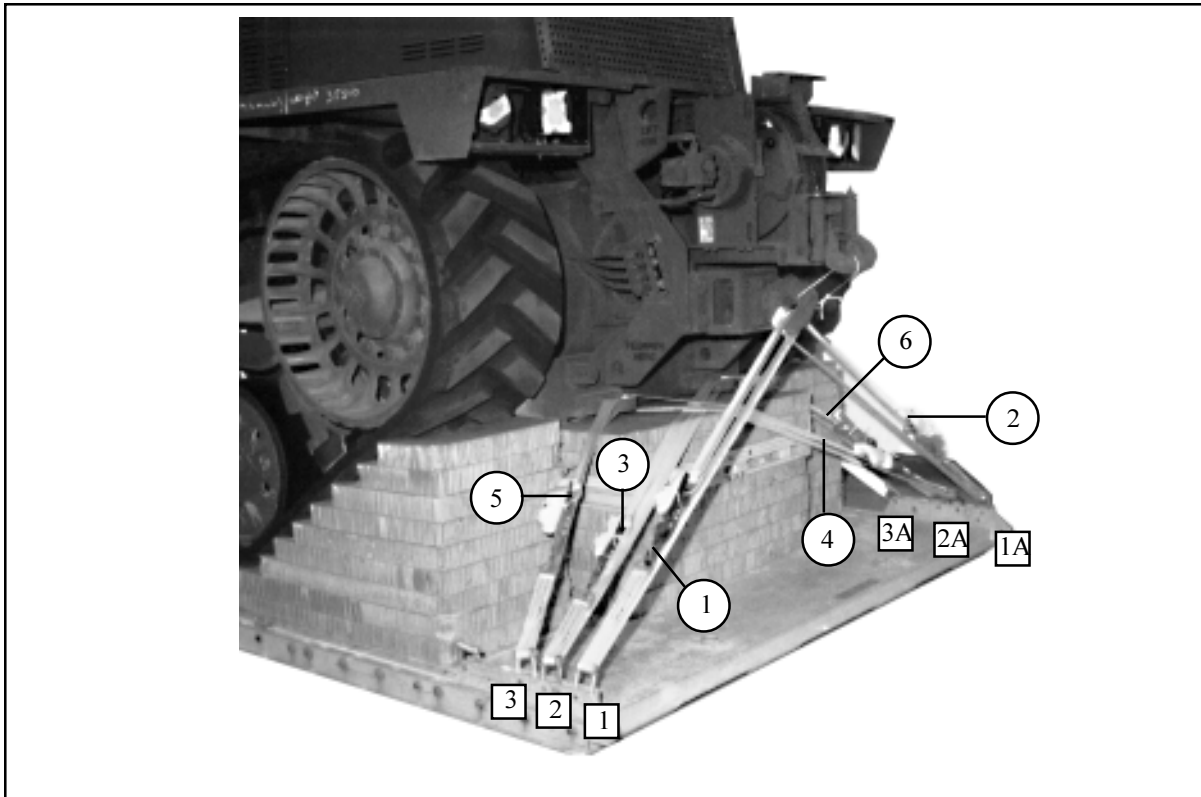

Figure 4-9. DEUCE Lifted and Positioned on Platform (Continued)

LASHING LOAD TO PLATFORM

4-6. Lash the DEUCE to the platform as shown in Figure 4-10.



Lashing Number	Tiedown Clevis Number	Instructions
		Pass lashing:
1	1	To tow pintle, left side.
2	1A	To tow pintle, right side.
3	2	To right rear tiedown.
4	2A	To left rear tiedown.
5	3	To left rear tiedown.
6	3A	To right rear tiedown.

Figure 4-10. DEUCE Lashed to Platform

NOTE: Ensure the lashings are routed under all hoses.

Lashing Number	Tiedown Clevis Number	Instructions
7	4	Route a 30-foot lashing over the left rear idler wheel, through the left rear portion of the recoil cylinder mount.
8	4A	Route a 30-foot lashing over the right rear idler wheel, through the right rear portion of the recoil cylinder mount.

Figure 4-10. DEUCE Lashed to Platform (Continued)

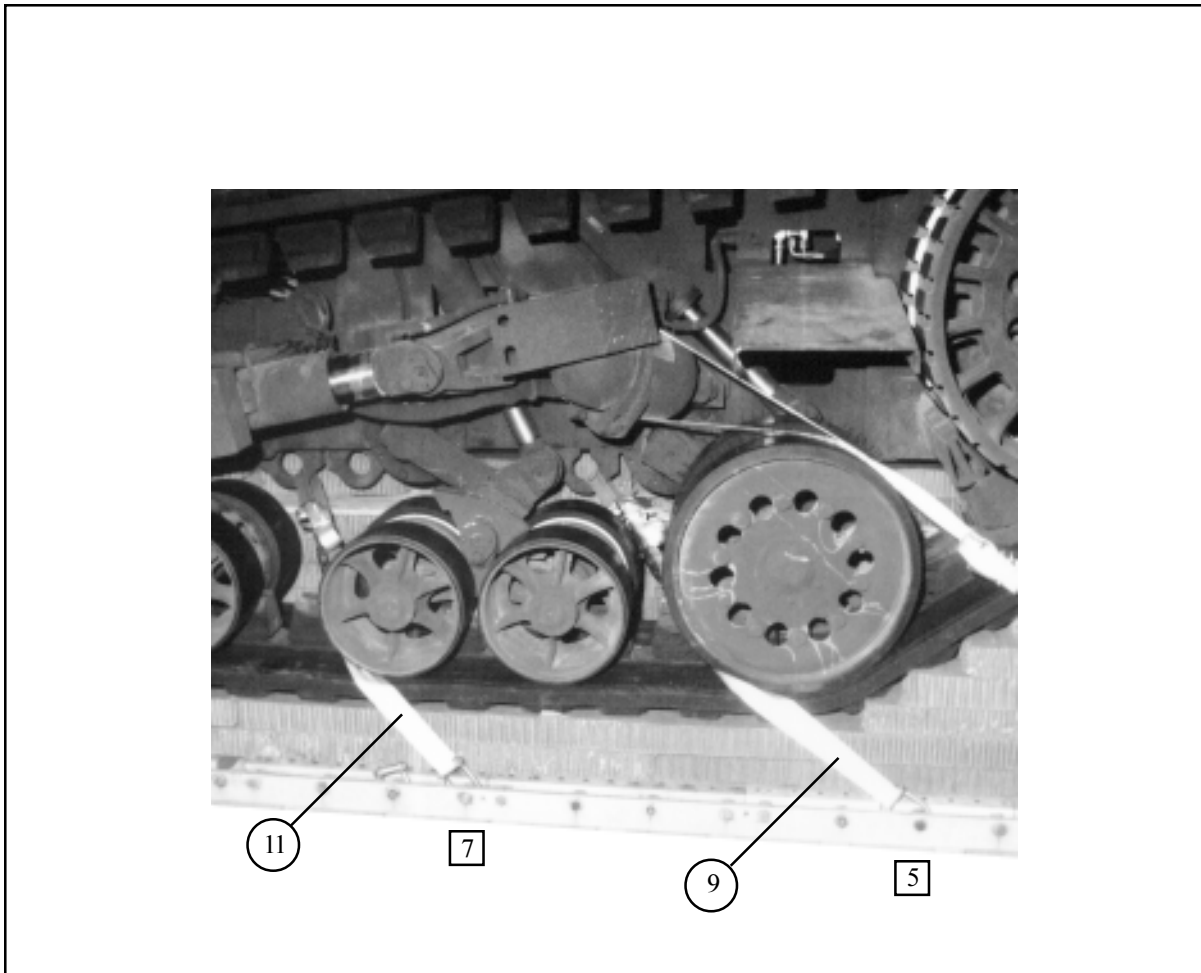

Lashing Number	Tiedown Clevis Number	Instructions
9	5	Pass lashing through: Rear frame tiedown, left side.
10	5A	Rear frame tiedown, right side.
11	7	Front frame tiedown, left side.
12	7A	Front frame tiedown, right side.

Figure 4-10. DEUCE Lashed to Platform (Continued)

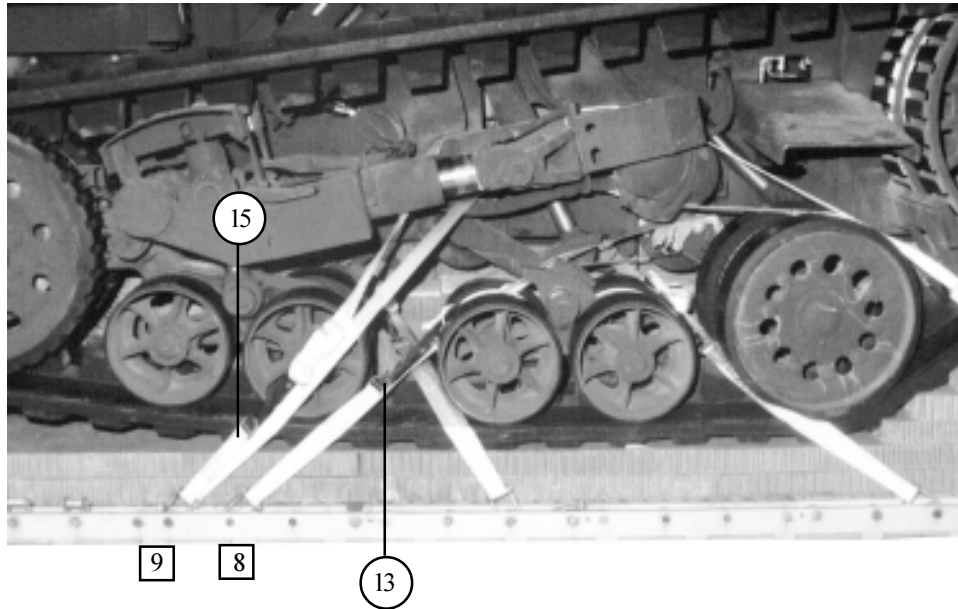

Lashing Number	Tiedown Clevis Number	Instructions
13	8	Pass lashing through: Rear axle mount, left side.
14	8A	Rear axle mount, right side.
15	9	Front portion of the recoil cylinder mount, left side.
16	9A	Front portion of the recoil cylinder mount, right side.

Figure 4-10. DEUCE Lashed to Platform (Continued)

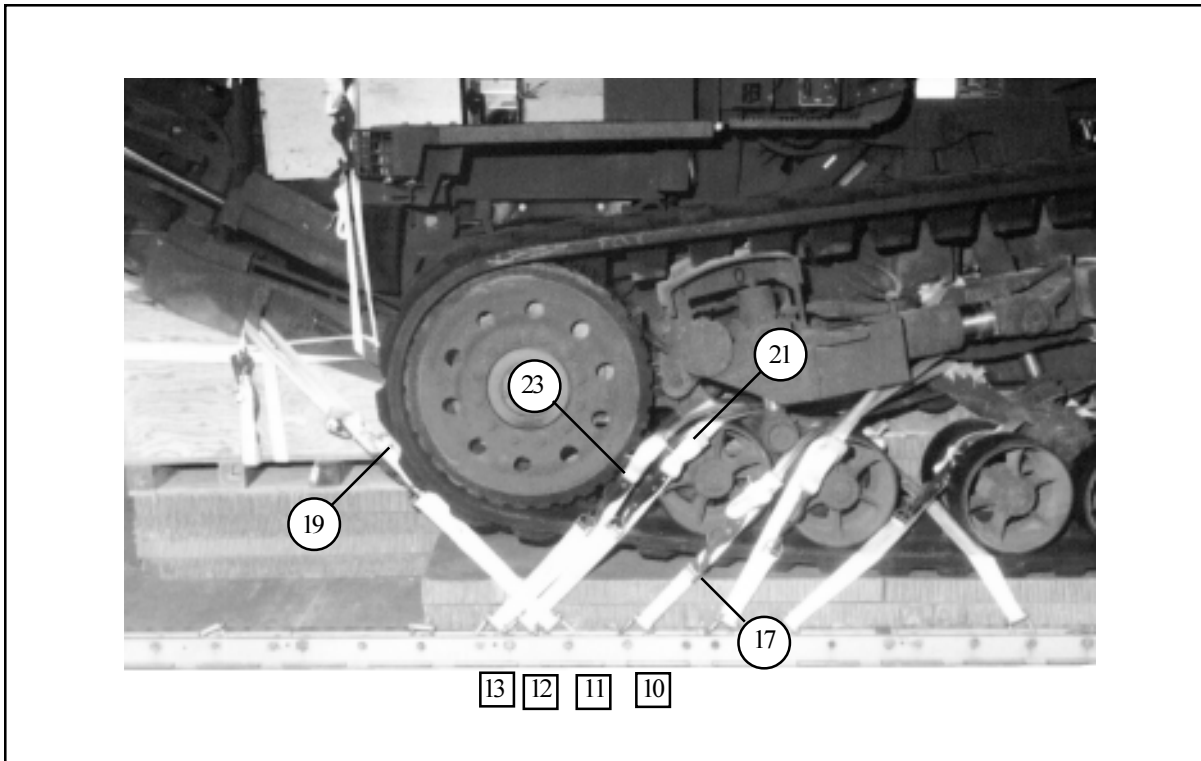

Lashing Number	Tiedown Clevis Number	Instructions
		Pass lashing through:
17	10	Center axle mount, left side.
18	10A	Center axle mount, right side.
19	11	C-frame lift point, left side.
20	11A	C-frame lift point, right side.
21	12	Center frame tiedown, left side.
22	12A	Center frame tiedown, right side.
23	13	Front frame tiedown, left side.
24	13A	Front frame tiedown, right side.

Figure 4-10. DEUCE Lashed to Platform (Continued)

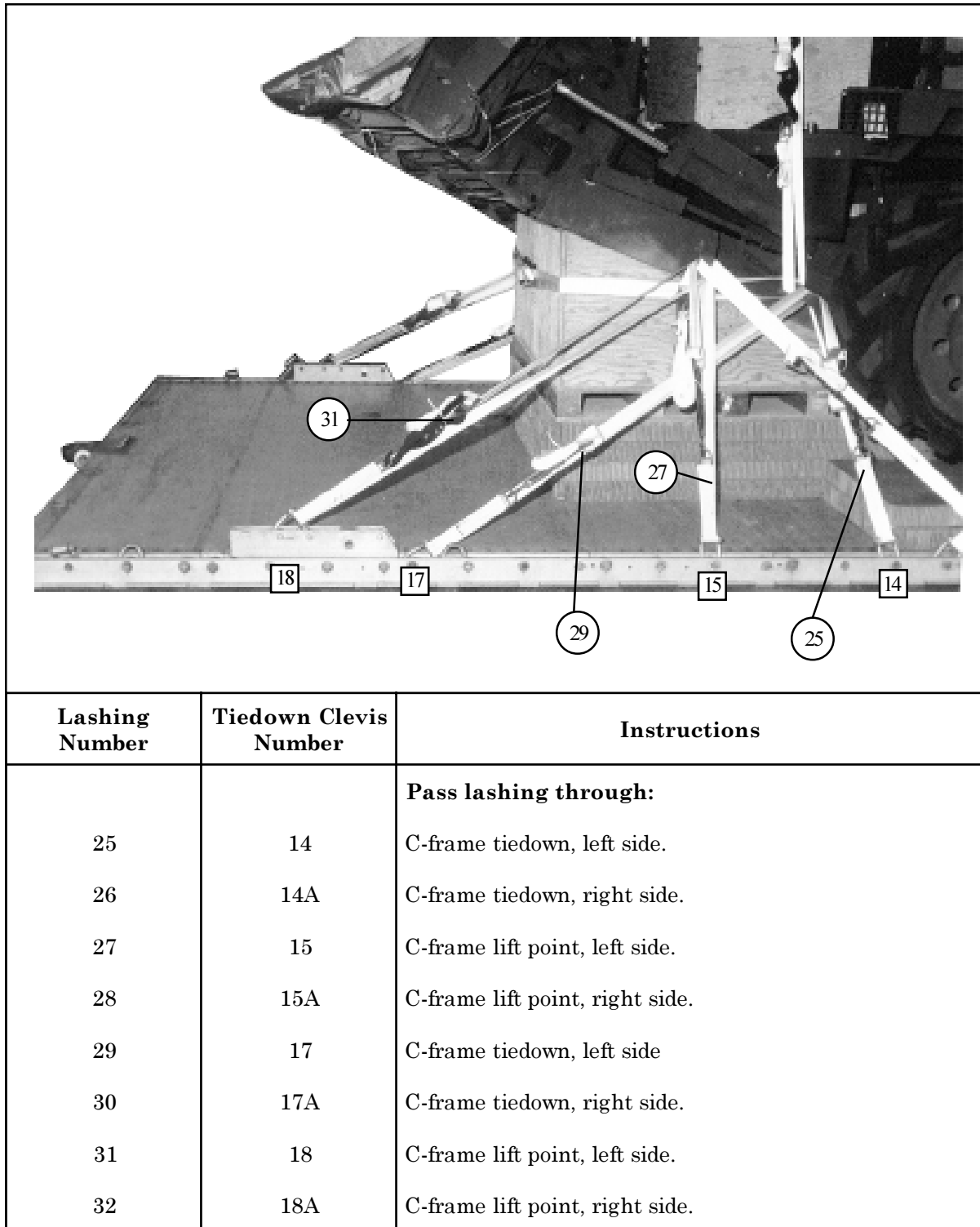

Lashing Number	Tiedown Clevis Number	Instructions
25	14	Pass lashing through: C-frame tiedown, left side.
26	14A	C-frame tiedown, right side.
27	15	C-frame lift point, left side.
28	15A	C-frame lift point, right side.
29	17	C-frame tiedown, left side
30	17A	C-frame tiedown, right side.
31	18	C-frame lift point, left side.
32	18A	C-frame lift point, right side.

Figure 4-10. DEUCE Lashed to Platform (Continued)

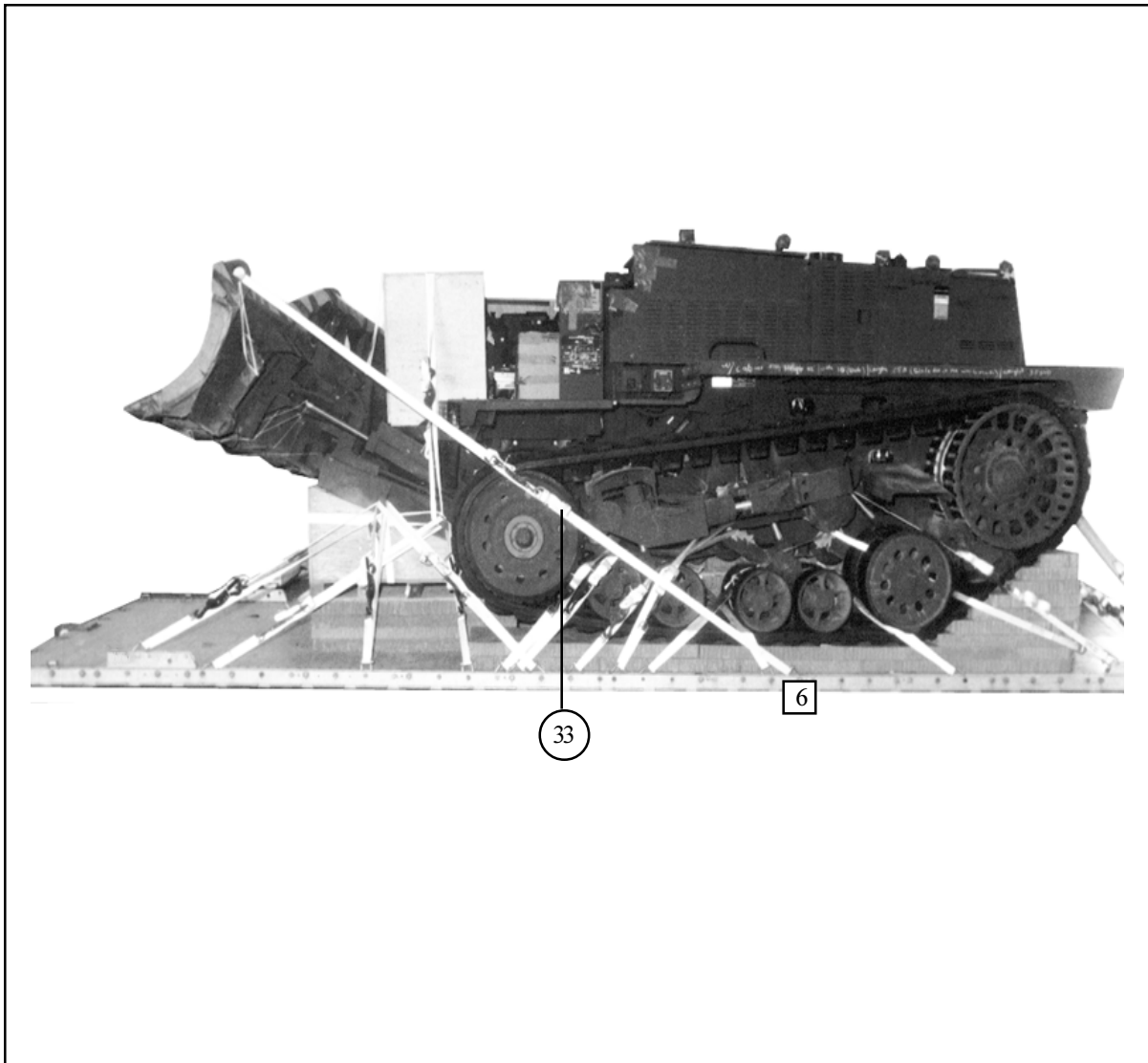

Lashing Number	Tiedown Clevis Number	Instructions
33	6	Route a 30-foot lashing through the blade lift point, left side.
34	6A	Route a 30-foot lashing through the blade lift point, right side.

Figure 4-10. DEUCE Lashed to Platform (Continued)

INSTALLING THE REAR STEP BOX AND LOAD COVER

4-7. Install the rear step box and load cover as shown in Figure 4-11.

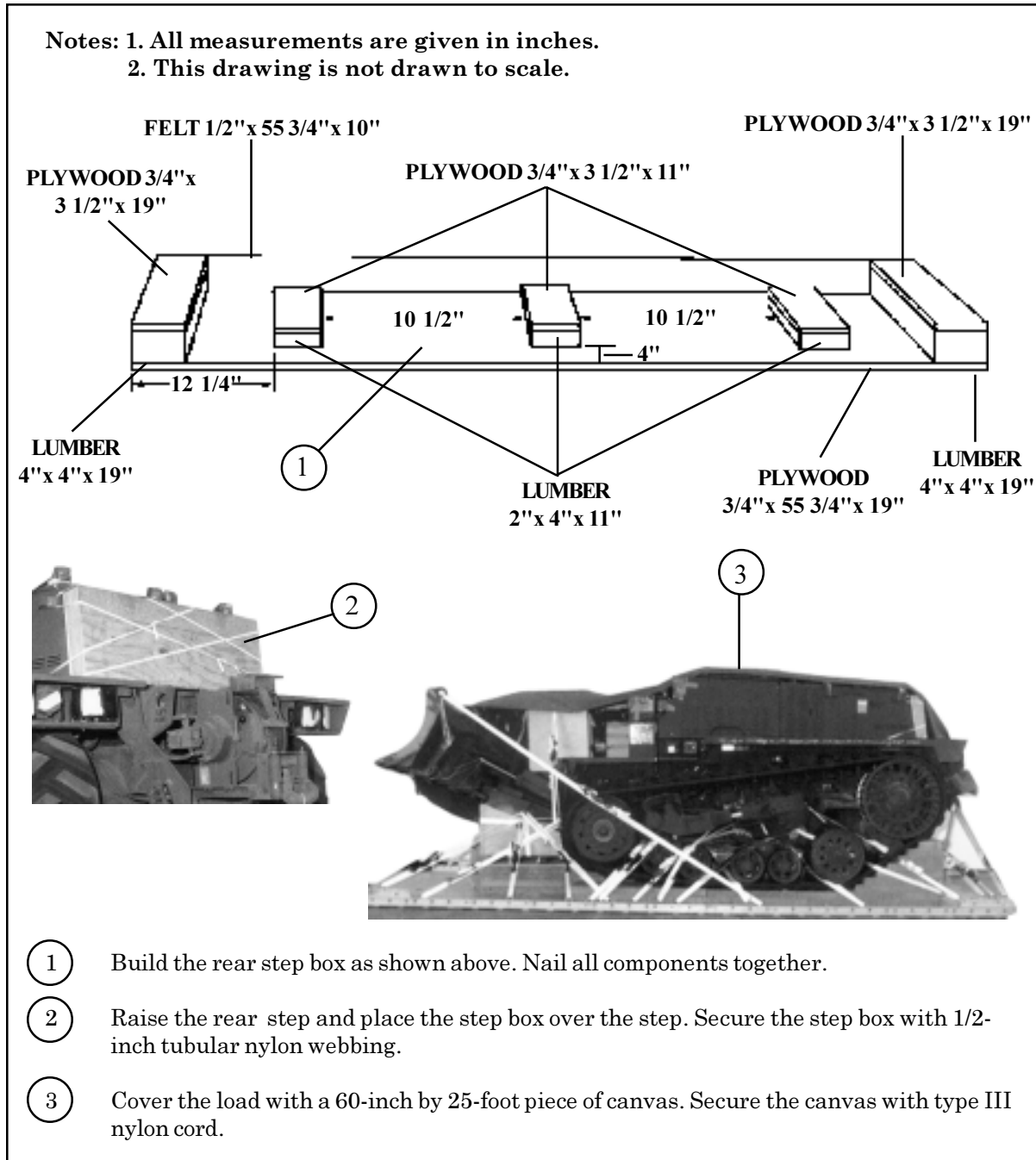

Figure 4-11. Rear Step Box Placed and Load Covered

INSTALLING SUSPENSION SLINGS AND DEADMAN'S TIE

4-8. Install the suspension slings and deadman's tie as shown in Figure 4-12.

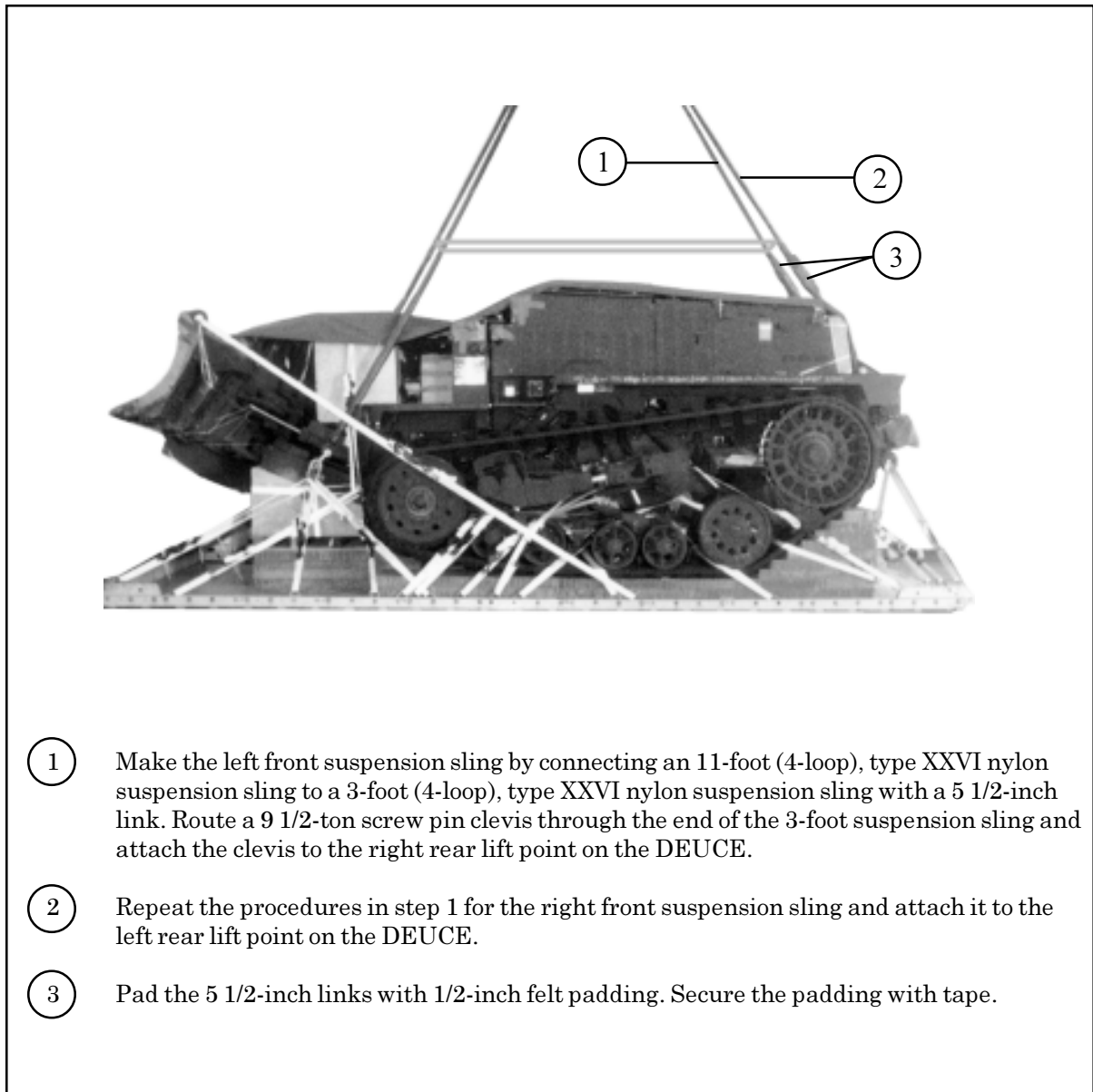
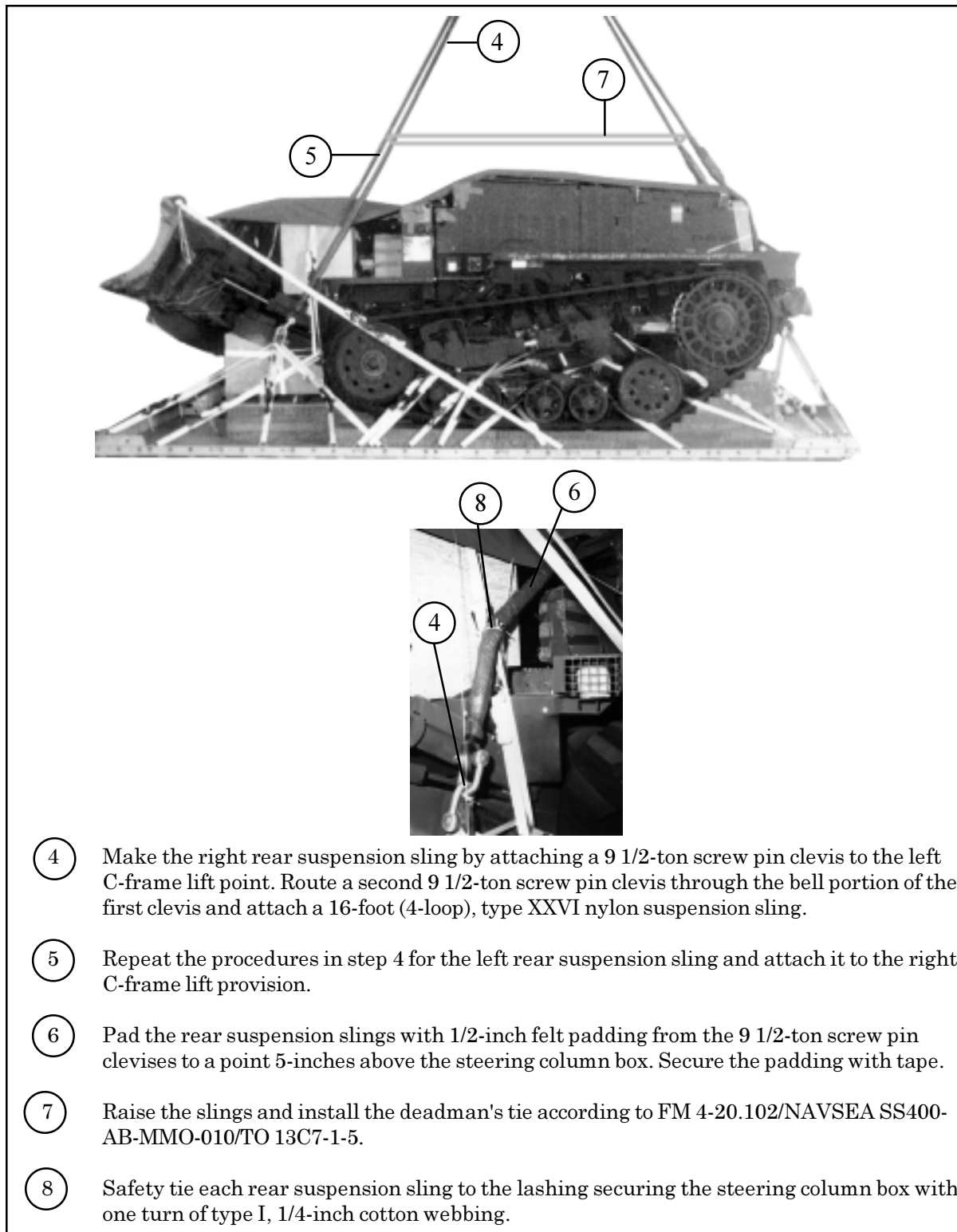

Figure 4-12. Suspension Slings and Deadman's Tie Installed



- ④ Make the right rear suspension sling by attaching a 9 1/2-ton screw pin clevis to the left C-frame lift point. Route a second 9 1/2-ton screw pin clevis through the bell portion of the first clevis and attach a 16-foot (4-loop), type XXVI nylon suspension sling.
- ⑤ Repeat the procedures in step 4 for the left rear suspension sling and attach it to the right C-frame lift provision.
- ⑥ Pad the rear suspension slings with 1/2-inch felt padding from the 9 1/2-ton screw pin clevises to a point 5-inches above the steering column box. Secure the padding with tape.
- ⑦ Raise the slings and install the deadman's tie according to FM 4-20.102/NAVSEA SS400-AB-MMO-010/TO 13C7-1-5.
- ⑧ Safety tie each rear suspension sling to the lashing securing the steering column box with one turn of type I, 1/4-inch cotton webbing.

Figure 4-12. Suspension Slings and Deadman's Tie Installed (Continued)

BUILDING AND POSITIONING PARACHUTE STOWAGE PLATFORM

4-9. Build and position the parachute stowage platform as shown in Figure 4-13.

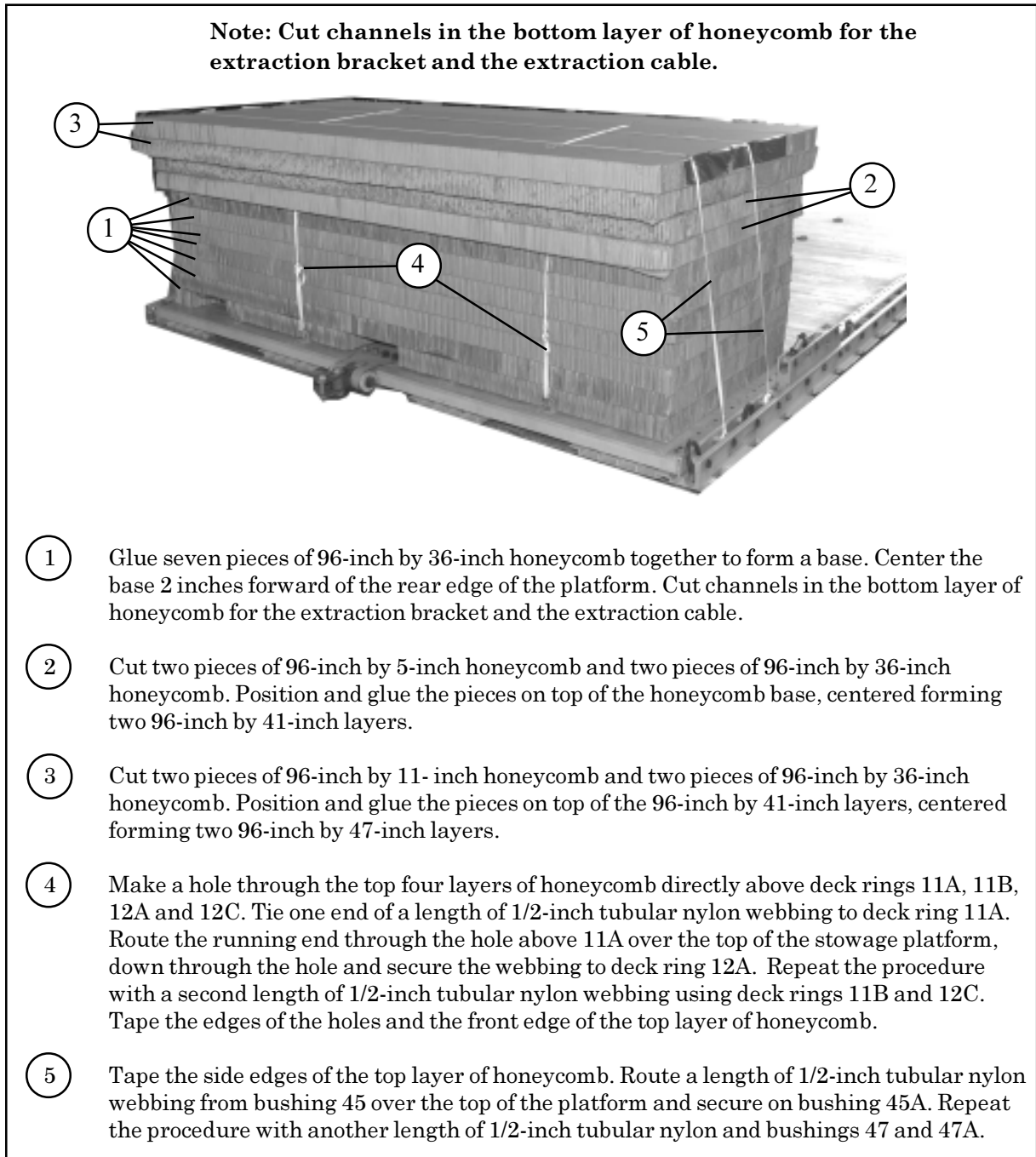

Figure 4-13. Parachute Stowage Platform Built and Positioned

PREPARING AND STOWING CARGO PARACHUTES

4-10. Prepare and stow the cargo parachutes as shown in Figure 4-14.

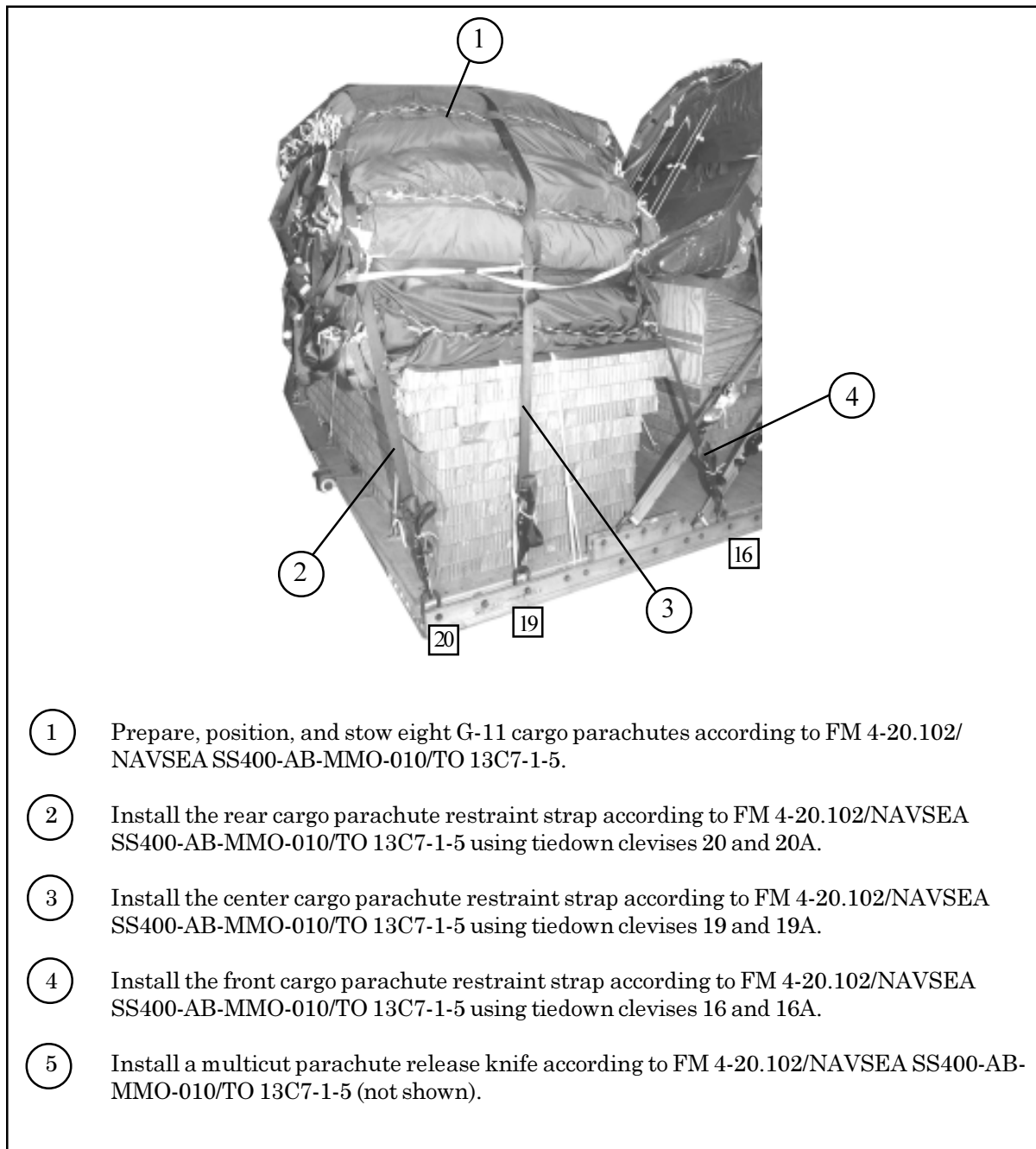

Figure 4-14. Cargo Parachutes Prepared and Stowed

INSTALLING EXTRACTION SYSTEM

4-11. Install the extraction system as shown in Figure 4-15.

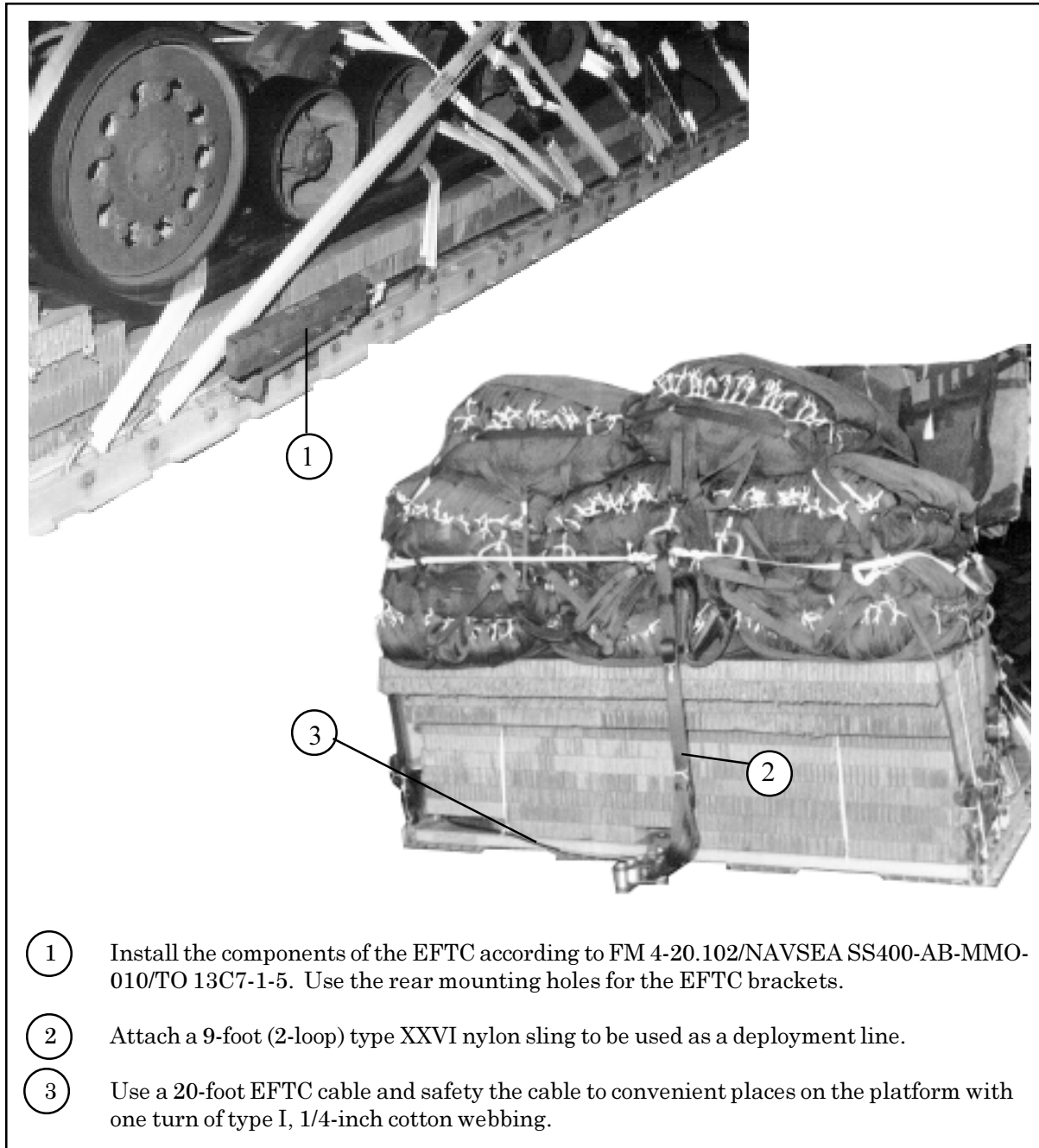

Figure 4-15. Extraction System Installed

INSTALLING PARACHUTE RELEASE

4-12. Prepare, attach, and safety an M-2 cargo parachute release according to FM 4-20.102/NAVSEA SS400-AB-MMO-010/TO 13C7-1-5 and as shown in Figure 4-16.

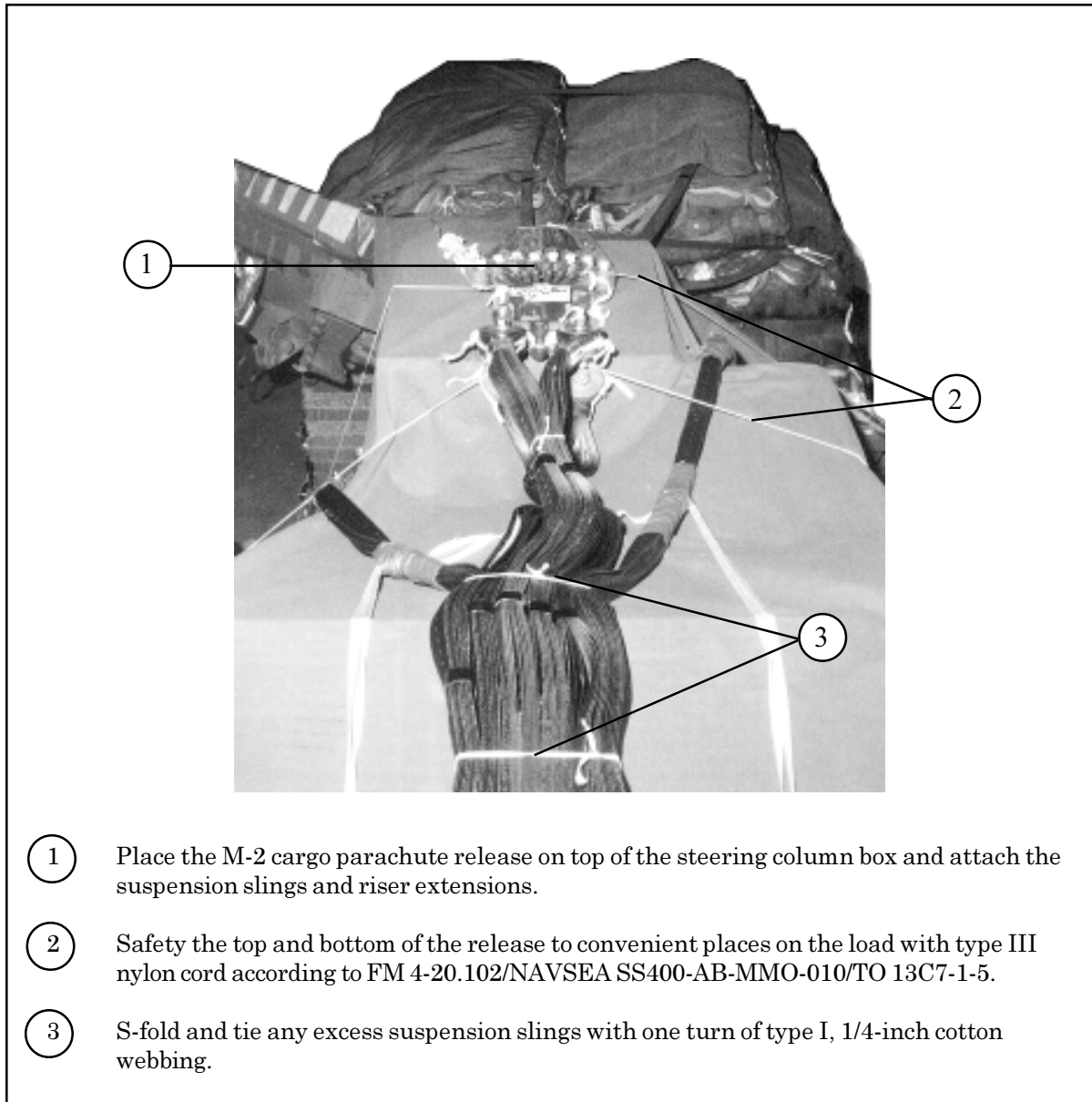

Figure 4-16. M-2 Cargo Parachute Release Installed

PLACING EXTRACTION PARACHUTE

4-13. Select the extraction parachute and extraction line needed using the extraction line requirements table in FM 4-20.102/NAVSEA SS400-AB-MMO-010/TO 13C7-1-5. Place the extraction parachute and line on the load for installation in the aircraft.

INSTALLING PROVISIONS FOR EMERGENCY RESTRAINTS

4-14. Select and install the provisions for the emergency aft restraints according to the emergency aft restraint requirements table in FM 4-20.102/NAVSEA SS400-AB-MMO-010/TO 13C7-1-5.

MARKING RIGGED LOAD

4-15. Mark the rigged load according to FM 4-20.102/NAVSEA SS400-AB-MMO-010/TO 13C7-1-5, and as shown in Figure 4-17. Complete Shipper's Declaration for Dangerous Goods. If the load varies from the one shown, the weight, height, CB, and parachute requirements must be recomputed.

EQUIPMENT REQUIRED

4-16. Use the equipment listed in Table 4-1 to rig this load.

CAUTION

1. Make the final rigger inspection required by FM 4-20.102/NAVSEA SS400-AB-MMO-010/TO 13C7-1-5 before the load leaves the rigging site.
2. Remeasure the width of the load after the load is placed on the 60K-Loader. Make sure the load has not shifted.
3. Prior to movement make sure all lashing are taut to prevent vehicle movement.

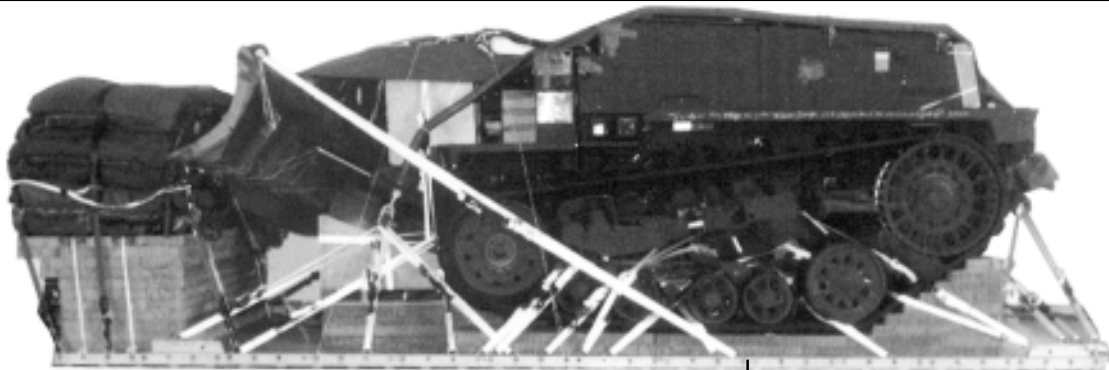

C/B

RIGGED LOAD DATA

Weight.....	40,340 pounds
Maximum Weight.....	40,800 pounds
Height.....	101 1/2 inches
Width.....	110 inches
Length.....	310 inches
Overhang: Front.....	0 inches
Rear.....	22 inches
Center of Balance (CB) (from front edge of the platform).....	122 inches
Extraction System.....	EFTC

Figure 4-17. Deployable Universal Combat Earthmover (DEUCE), Rigged on a 24-Foot Platform for Low-Velocity Airdrop

Table 4-1. Equipment required for rigging the Deployable Universal Combat Earthmover on a 24-foot type V platform for low-velocity airdrop

National Stock Number	Item	Quantity
1670-00-162-4982	Adapter, latch assembly, side plates, 11-inch (modified) (C-5 only)	2
8040-00-273-8713	Adhesive paste, 1-gal.	As required
4030-00-432-2516	Clevis, screw-pin, large	6
4030-00-090-5354	Clevis, suspension, 1-inch (large)	6
8305-00-880-8155	Cloth, coated (nyl, type II, 17.0 oz, green, 60-in)	As required
4020-00-240-2146	Cord, nylon, type III, 550-lb.	As required
1670-00-434-5787	Coupling, airdrop extraction force transfer, w/20-ft. cable	1
1670-00-360-0328	Cover, clevis	9
8135-00-664-6958	Cushioning material (Cellulose padding)	As required
8305-00-958-3685	Felt, 1/2-inch thick	As required
1670-01-183-2678	Leaf, extraction line (line bag) (add 2 for C-17)	2
	Line extraction:	
1670-01-064-4454	60-foot (6-loop), type XXVI (for C-130)	1
1670-01-062-6312	120-foot (6-loop), type XXVI, (for C-5 between fuselage stations 1667-1971)	1
1670-01-062-6312	120-foot (6-loop), type XXVI and	1
1670-01-064-4454	60-foot (6-loop), type XXVI, (for C-5 between fuselage stations 947-1666)	1
1670-01-062-6312	120-foot (6-loop), type XXVI, (for C-5 between fuselage stations 574-947)	2
1670-01-468-9178	140-foot (6-loop), type XXVI (for C-17)	1
1670-01-064-4452	60-foot (1-loop), type XXVI (for C-17), (drogue line)	1
1670-00-783-5988	Link assembly, type IV (C-17 only)	1
	Link assembly, two-point:	
5306-00-435-8994	Bolt, 1-inch diameter, 4-inches long (add 4 for C-5)	4
5310-00-232-5165	Nut, 1-inch (add 4 for C-5)	4
1670-00-003-1954	Plate, side, 5 1/2-inch	4
5365-00-007-3414	Spacer, large (add 4 for C-5)	4
1670-00-006-2752	Link, four-point	1
	Lumber:	
5510-00-220-6146	2- by 4- by 11-inch	3
	2- by 4- by 24 1/4-inch	2
	2- by 4- by 30 3/4-inch	2
	2- by 4- by 41 3/4-inch	8

Table 4-1. Equipment required for rigging the Deployable Universal Combat Earthmover on a 24-foot type V platform for low-velocity airdrop (Continued)

National Stock Number	Item	Quantity
5510-00-220-6274	Lumber: 4- by 4- by 2 3/4-inch 4- by 4- by 7-inch 4- by 4- by 8-inch 4- by 4- by 11 1/4-inch 4- by 4- by 15 3/4-inch 4- by 4- by 19-inch 4- by 4- by 20-inch 4- by 4- by 48-inch	2 2 1 2 2 2 2 5
5315-00-010-4659	Nail, steel, common, 8D	As required
5315-00-753-3885	Nail, steel, common, 16D	As required
1670-00-753-3928	Pad, energy-dissipating (honeycomb) 3- by 36- by 96-inches 35 sheets	
1670-01-016-7841	Parachute, cargo, G-11C	8
1670-00-040-8135	Parachute, cargo, extraction: 28-ft.	2
1670-01-063-3715	15-ft. (C-17 only)	1
1670-01-162-2372	Platform, airdrop, type V, 24-ft:	
1670-01-162-2376	Clevis assembly (type V)	(42)
1670-01-162-2376	Extraction bracket assembly	(1)
1670-01-247-2389	Link, suspension bracket, type V	(2)
1670-01-162-2381	Tandem link assembly (Multipurpose link)	(2)
5530-00-128-4981	Plywood, 3/4-inch:	9 sheets
1670-01-097-8817	Release, cargo parachute, M-2	1
1670-01-062-6306	Sling, cargo, airdrop: 3-ft. (4-loop), type XXVI	5
1670-01-062-6304	9-ft. (2-loop), type XXVI	1
1670-01-062-6310	11-ft. (4-loop), type XXVI	2
1670-01-062-6307	12-ft. (4-loop), type XXVI	2
1670-01-062-6308	16-ft. (4-loop), type XXVI	6
1670-01-062-6311	120-ft. (2-loop), type XXVI	8

Table 4-1. Equipment required for rigging the Deployable Universal Combat Earthmover on a 24-foot type V platform for low-velocity airdrop (Continued)

National Stock Number	Item	Quantity
5340-00-040-8219	Strap, parachute, release, multi-knife	2
7501-00-266-5016	Tape, adhesive, 2-inch	As required
1670-00-937-0271	Tiedown assembly, 15-ft.	49
1670-01-483-8259	Towplate release mechanism (H-block) (C-17 only)	1
	Webbing:	
8305-00-268-2411	Cotton, 1/4-inch, type I	As required
8305-00-082-5752	Nylon, tubular, 1/2-inch	As required
8305-00-260-6890	Nylon, type X	As required
8305-00-268-2455	Nylon, tubular, 1-inch, OD 7	As required

GLOSSARY

ACB	attitude control bar
AD	airdrop
AFB	Air Force base
AFR	Air Force regulation
AFTO	Air Force technical order
attn	attention
CB	center of balance
d	penny
DA	Department of the Army
DC	District of Columbia
DD	Department of Defense
diam	diameter
DEUCE	Deployable Universal Combat Earthmover
EFTA	extraction force transfer actuator
EFTC	extraction force transfer coupling
FM	field manual
ft	foot
gal	gallon
HQ	headquarters
in	inch
lb	pound
LV	low-velocity
no	number
NSN	national stock number
OVM	operator vehicle maintenance
psi	pounds per square inch
ROPS	roll-over protection structure
SL/CS	static line/connector strap
TBD	to be determined
TM	technical manual
TO	technical order
TRADOC	United States Army Training and Doctrine Command
US	United States
w	with

REFERENCES

*AFMAN(I) 24-204/TM 38-250. Preparing Hazardous Materials for Military Air Shipments. December 2001.

**FM 4-20.102/NAVSEA SS400-AB-MMO-010/TO 13C7-1-5. Airdrop of Supplies and Equipment: Rigging Airdrop Platforms. June 2001.

TM 5-2410-231-10 Operator's Manual: Tractor, Full Tracked, Low Speed, DED, 16,000 to 24,900 lb Drawbar Pull, 60 Inch Min Gage, Sectionalized, Air Transportable (Caterpillar Model D5) (FSN 2410-828-6865). August 1968.

TM 10-1670-268-20&P/TO 13C7-52-22. Organizational Maintenance Manual With Repair Parts and Special Tools List: Type V Airdrop Platform. 1 June 1986.

TM 10-1670-277-23&P/TO 13C5-28-2/NAVAIR 13-1-30. Unit and Direct Support (DS) Maintenance Manual Including Repair Parts and Special Tools List for Parachute, Cargo Type, 28-ft Diam, Cargo Extraction. 9 October 1990.

TM 10-1670-278-23&P/TO 13C5-26-2/NAVAIR 13-1-27. Unit and Intermediate DS Maintenance Manual Including Repair Parts and Special Tools List for Parachute, Cargo Type, 15-ft Diam, Cargo Extraction. 6 November 1989.

TM 10-1670-279-23&P/TO 13C5-27-2/NAVAIR 13-1-28. Unit and Intermediate DS Maintenance Manual Including Repair Parts and Special Tools List for Parachute, Cargo Type, 22-ft Diam, Cargo Extraction. 30 August 1989.

TM 10-1670-280-23&P/TO 13C5-31-2/NAVAIR 13-1-31. Unit and Intermediate DS Maintenance Manual Including Repair Parts and Special Tools List for Parachute, Cargo Type, G-11A, G-11B, and G-11C. 5 August 1991.

TM 10-1670-286-20/TO 13C5-2-41. Unit Maintenance Manual for Sling/Extraction Line Panel (Including Stowing Procedures). 1 April 1986.

AFTO Form 22. Technical Order Publication Improvement Report

DA Form 2028. Recommended Changes to Publication and Blank Forms. February 1974.

*** Shipper's Declaration for Dangerous Goods. Locally procured form

*AFMAN(I) 24-204/TM 38-250 has superseded AFJMAN 24-204/TM 38-250 (15 January 1988). This revision reflects this change.

**FM 4-20.102/NAVSEA SS400-AB-MMO-010/TO 13C7-1-5 has superseded FM 10-500-2/TO 13C7-1-5 (1 November 1990). This revision reflects this change.

*** Shipper's Declaration for Dangerous Goods has superseded DD Form 1387-2 (February 1982.) This revision reflects this change.

FM 4-20.121 (FM 10-521)
TO 13C7-6-21
20 MARCH 2003

By Order of the Secretary of the Army and the Air Force:

ERIC K. SHINSEKI

General, United States Army
Chief of Staff

Official:

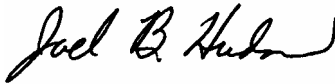

JOEL B. HUDSON

Administrative Assistant to the
Secretary of the Army

0307108

LESTER L. LYLES
General, USAF
Commander, AFMC

JOHN P. JUMPER
General, USAF
Chief of Staff

DISTRIBUTION:

Active Army, Army National Guard, and US Army Reserve: To be distributed in accordance with the initial distribution number 110904, requirements for FM 4-20.121.

PIN: 080685-000